

Sounds to signalise end of charge:

Sound Nr: 1
Play = START Key

There is a choice of 10 different melodies for signalling. Pressing the **Start**-button will play the selected melody.

Sound Repeat
Rate: 0 sec

Sound repeat will select the time to repeat the signal after charging is completed and may be set between 0 and 50 seconds. This will make sure that any accidental cut-off will be noticed. To switch off the signal press any key or disconnect the battery.

CHARGING

Connecting a battery:

Connect the battery to charge to the front side wires - red to the positive (+) pole and black to the negative (-) pole. Reverse connecting the battery sounds an alarm.

To start charging:

Correctly connected batteries will show "RDY" and the battery voltage on the multifunctional display. Pressing the Start-button will start the charging process. The control LED lights up to confirm the charging process. The charging current, battery voltage, temperature and time elapsed since start will be shown on the display.

End of charging:

Charging will be terminated automatically whenever the Delta Peak voltage or the preset temperature is reached and will be made heard by a melody. The time for charging and charged capacity will be shown on the display. To manually terminate the charging process just press the **Start**-button again (LED goes off).

Preset profiles:

No.	Method	Current setting	Delta Peak	Peak-Lock	Temperature	Trickle	Best for
1	Linear	5.0A	8mV/cell	0min	50°C	No	NiMH
2	EXP-3P	9.0A / 6.0A / 4.0A			50°C	No	NiMH
3	Linear	5.0A	20mV/cell	0min	50°C	Yes	NiCd
4	EXP-3P	9.0A / 6.0A / 4.0A			50°C	Yes	NiCd
5	Linear	4.5A	8mV/cell	5min	50°C	No	NiMH reduced current setting
6	EXP-3P	7.5A / 4.5A / 3.5A			50°C	No	NiMH reduced current setting

TIP:

For better battery care we recommend our **Robitronic Equalizer Discharge Tray** (# RS111). Regular use of our discharge tray should prolonge lifetime and enhance performance of your packs.

Specifications:

- Quick single cell discharge of saddle or side-by-side packs.
- Automatic cut-off at 0,8 V/cell to prevent deep discharge.
- Equalises discharge level for all cells.
- LED indicator for single cells.
- Suited for packs with or without soldered socket connectors.



TROUBLESHOOTING

Asterix in current display:

Whenever an asterix is shown on the display near the charging current the current had to be reduced because of overload conditions. To correct this problem reduce the supply voltage or reset the charging current to a lower setting.

Wrong display of temperature:

Strange or constantly changing values for the temperature display indicate a broken wire to the probe. As this may lead to false cut-off one should disable the temperature cut-off as a quick work-around. Repair of the defective temperature probe is recommended.

Charging won't start:

"OFF" is still displayed after pressing the **Start**-button: Check for correct connections, broken wires or defective cells.

Robitronic EXPERT Charger - Instructions (Please read through before first use)

Features:

- EXP-3P-Software for Expert-charging control in 3 steps
- Programmable charging modes for NiMH and NiCd batteries
- Charging capability: 4 to 8 cell packs
- Charge rate adjustable between 0,1 and 10 Amps
- Peak voltage and/or temperature cut-off detection (may be used in combination)
- 6 different pre-programmed charge profiles (may be modified individually)
- Backlit multifunctional display
- Display of input voltage, charge time, capacity, charge current, battery voltage, peak voltage and battery temperature
- Internal resistance is displayed when using EXP-3P mode
- Automatic charge resume after power source failure
- Built-in delay timer for programmable start of charging
- Adjustable trickle charge rate (may be switched off for NiMH)
- Input Voltage between 12 and 15 V= (automotive battery or stabilised power supply)
- Overload protected power MOSFETs
- Reverse voltage protection circuit
- Select one out of 10 melodies to signalise "charging completed"
- User selectable repeat rate for charging completed melody
- Choice of temperature display in Celsius or Fahrenheit

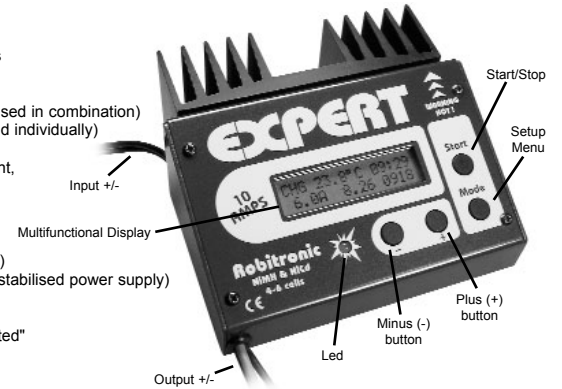

General information:

The Robitronic Expert is a computerised high performance charger. It was developed with ergonomics and reliability in mind. The backlit multifunctional display provides total information about the charging progress and the state of the battery on charge.

ATTENTION

When using high current settings internal pressure may build up during the recharging process causing a risk of explosion when charging old or defective cells. Therefore always keep the charger and batteries on charge well away from small children. When charging from an automotive battery avoid contact between output leads and car body. Positive wire is connected straight through from input to output shorting out the car battery when this happens.

CONNECTIONS

Connect the red wire (positive) and the black wire (negative) from the backside(!) of the Expert Charger to a suitable power supply. Suitable power supplies are automotive batteries or stabilised power supplies with a high enough output current rating and an output voltage between 12 and 15 V=.

Connecting the charger the wrong way will trigger an electronic protection circuit. If this happens there is no need to change a blown fuse, just connect the charger correctly (red wire to + and black wire to -).



Attaching the temperature probe

MULTIFUNCTIONAL DISPLAY

Overview:

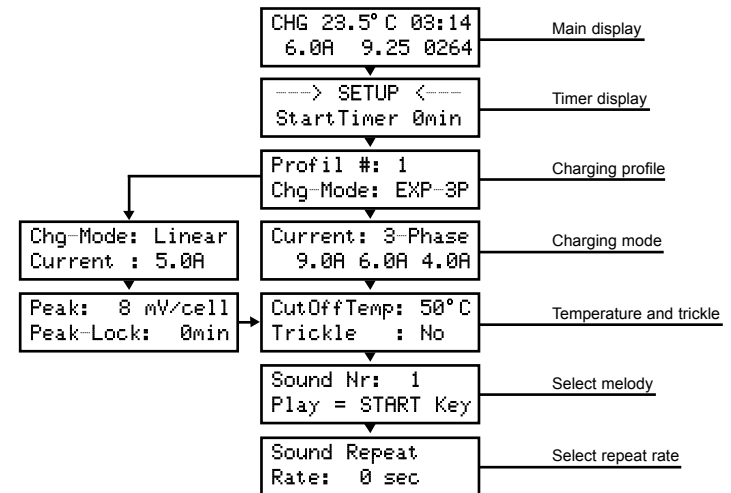

With no battery connected, "OFF" status and supply voltage will be shown on the display.

Status display:

- OFF OFF - No battery connected
- CHG Charge - Charging
- RDY Ready - Charging completed
- TRK Trickle - Trickle charging
- ERR Error - Battery connection wrong or supply voltage too low

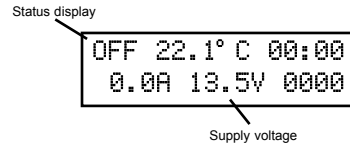

Display during charge in progress:

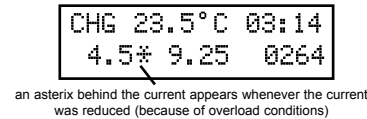
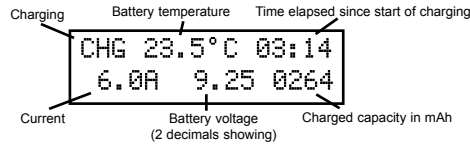

an asterix behind the current appears whenever the current was reduced (because of overload conditions)

Display when charging is completed:

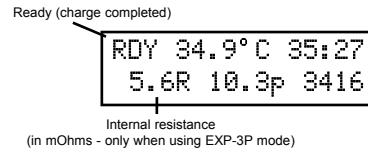
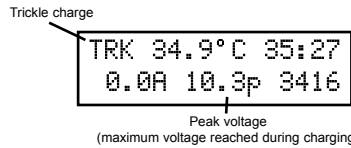

Calculation and display of internal resistance is only possible when using the EXP-3P mode for charging. Lower internal resistance stands for higher voltage output during discharge and therefore higher revs. Peak voltage is the maximum voltage reached during the charging process, a higher peak voltage is also a sign for higher internal resistance.

Switching the temperature display from Celsius to Fahrenheit (and back to Celsius):

To change the units for the temperature display just hold down the (-) button when powering on the charger. This setting will be stored even when disconnecting the power supply.

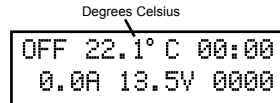
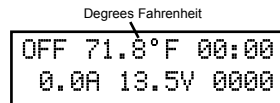

Warnings and errors:

Whenever the power supply voltage is low or a battery is reverse connected the message "ERR" will be shown and a warning sound will be heard. If the power supply is interrupted during charging, the process will resume automatically after the power supply is on and stabilised again.

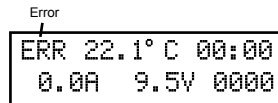

SETTINGS

Setting the parameters for charging:

Switch to Set Up Mode by pressing the **Mode**-button - the display will change to show the programmed settings. Press the **Mode**-button again to shift the cursor (= underline) to the next parameter. To change any underlined parameter press the **Plus (+)** or **Minus (-)** button.

Saving the parameters:

To store the modified parameters into memory hold down the **Mode**-button when pressing the **Start**-button again. When writing to memory is completed there will be a signal heard. Settings stored to memory will be loaded whenever the charger is connected to a power supply.

To use the new parameters without saving to memory just press the **Start**-button again to quit the Set Up Mode.

Delay timer:



To activate the programmable delay timer switch to Set Up Mode. Select a value between 0 and 99 minutes for the delay before starting a new charge. This works similar to a tea timer. Charging will start after the count down timer reached 0. This delayed charging procedure is especially useful for competition racing where charging "to the minute" is essential. And you will never again have to race with a battery charged only partially.

To start the countdown just press the **Start**-button. A blinking colon shows when the countdown is running. The delay timer will be reset to 0 after activation but the selected delay time is not saved to memory (it has to be set newly whenever the delay timer is used).

Charging modes:

6 different charging profiles (settings) may be stored to the built-in memory to give a personalised and convenient choice of charging modes for NiMH and NiCd batteries.

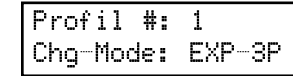
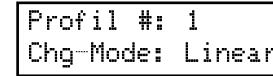

Linear mode and EXP-3P profile:

There is a choice between the conventional linear charging mode using constant current or the sophisticated EXP-3P profile developed by Robitronic. "EXP-3P" stands for "Expert 3-Phase Charging", a software programme to optimise the current setting depending on the status of the battery on charge.

- Phase 1: battery is charged with a very high current (8 - 9 Amps) to gain maximum voltage under load (during discharge)
- Phase 2: battery is charged as in linear mode (current is 5 - 6 Amps)
- Phase 3: current is reduced to 3 - 4 Amps to enhance capacity

Using 3 charging phases in combination with different current settings will result in higher output voltage and increased capacity (compared to conventional charging modes using one constant current setting only).

Adjusting the charge current:

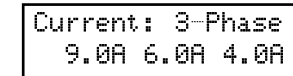
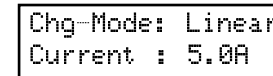

When using the EXP-3P profile there is a need to adjust the current settings for all 3 phases separately. Current setting for phase 1 should be as high as possible - depending on the ability of the power supply in use to deliver high currents.

Peak Voltage and Peak-Lock timer setting:

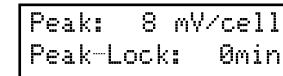

Peak voltage and Peak-Lock timer may be set only in Linear Mode, when using EXP-3P mode the peak voltage setting will be adjusted automatically to the battery on charge. Peak setting is used to determine the Delta Peak voltage for cut-off and should be selected according to the battery to be charged. For NiMH batteries a value of 8 mV/cell and for NiCd batteries 20 mV/cell are recommended. The range for the Delta Peak detection may be set between 4 mV/cell and 40 mV/cell. Delta Peak detection may be deactivated to cut-off on temperature only.

Peak-Lock is set to block out Delta Peak detection for a certain time to allow reliable charging of older battery packs with inconsistent voltage characteristics in Linear Mode.

Cut-Off temperature setting:

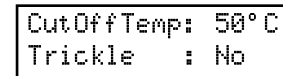

Temperature cut-off may be selected as an extra safety feature by attaching the provided temperature probe to the battery. Temperature cut-off may be disabled by increasing the value until "OFF" shows in the display.

When charging in EXP-3P mode the use of the temperature probe is strongly recommended because of the high current settings used in phase 1.

Trickle charging:

Continued charging with short pulses after the regular charge is only recommended for NiCd batteries.