

NAME: Marc KREPSIG
 RACE: BURSA DATE: 03.14.2011

TRACK

SIZE: OPEN MEDIUM TIGHT
 TRACTION: HIGH MEDIUM LOW
 TYPE: SMOOTH MEDIUM BUMPY
 TECHNICAL SLOW FAST
 CONDITION: DRY DUSTY WET MUD
 TEMPERATURE: AIR: 39° TRACK: 60°

DIFFERENTIALS

FRONT CENTER REAR
SOLID SOLID OPEN

SHOCK SPRINGS

FRONT SOFT
 MEDIUM
 HARD REAR

OIL VISCOSITY

FRONT 300 REAR 500

PISTON HOLE SIZES

FRONT 3x mm mm mm
 4x mm mm mm
 5x mm mm mm

ACKERMEN

X4

ANTI-ROLL BAR

FRONT 4 THICKNESS 4 REAR

TRANSMISSION RATIO

1: 6.06

Ratio	A	B	C	D
4.90	37	26	25	24
5.06	30	33	30	19
5.21	35	26	26	23
5.37	37	28	24	23
5.52	37	28	24	23
5.78	27	28	33	23
5.85	33	30	26	23
6.00	35	28	24	23
6.23	32	31	26	23
6.34	33	30	25	24
6.55	26	37	30	19
6.57	35	28	23	26
6.64	31	32	26	23
6.76	32	31	25	24
6.88	33	30	24	25
7.07	30	33	26	23
7.20	31	32	25	24
7.34	32	31	24	25
7.47	33	30	23	26
7.68	30	33	25	24
7.82	31	32	24	25
7.96	32	31	23	26
8.04	28	35	26	23
8.07	37	26	19	30
8.33	30	33	24	25
8.48	31	32	23	26
8.72	28	35	25	24

TYRES

ROSSA®
 MICRO-STUD®
 BLOCK-STUD®
 OTHER:

COMPOUND FBSR RBSR
 INSERT FSTD RSTD

Ø 145mm

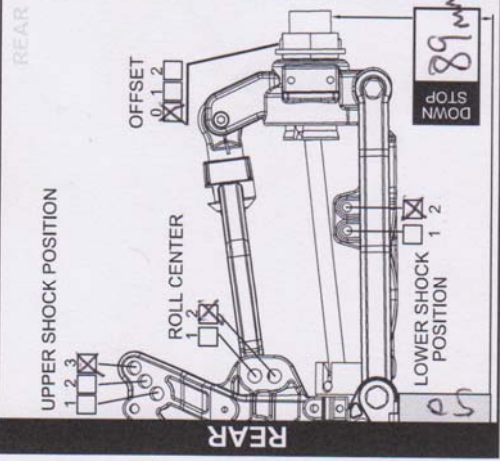
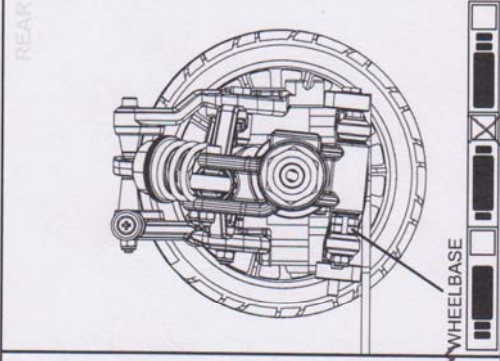
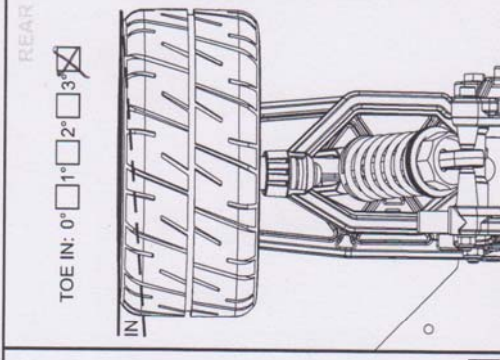
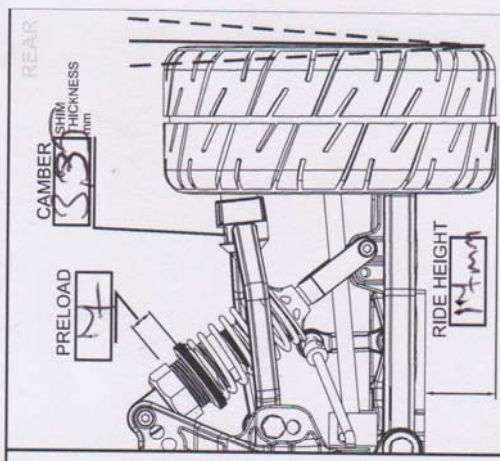
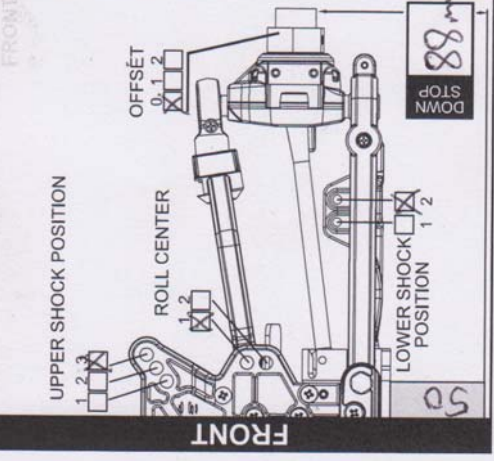
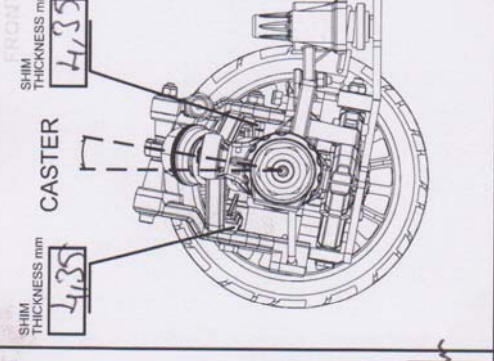
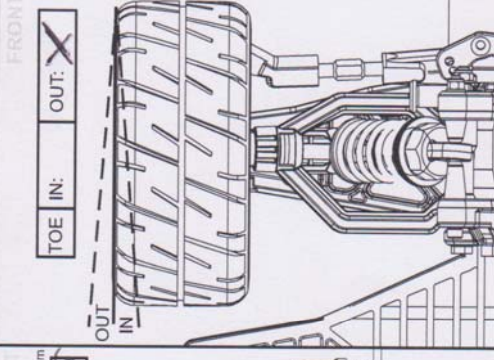
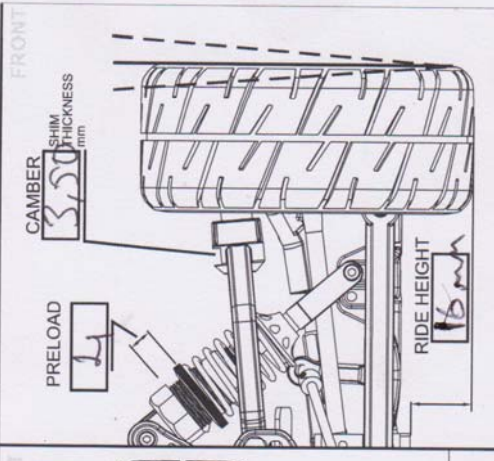

POSITION: _____ **BEST LAP:** _____

NOTES

POWER UNIT

ENGINE: CY240
 CARBURATOR: H L 50 L 1,05
 PLUG: NGK ECR 4H
 OIL: CASTOR
 CLUTCH: STD RED
 PIPE: SAMBA

TYRES

ROSSA®
 MICRO-STUD®
 BLOCK-STUD®
 OTHER:

COMPOUND FBSR RBSR
 INSERT FSTD RSTD

Ø 145mm

