



*1/10th Scale 2wd Electric Off Road Racing Truck*



# *Owner's Manual*



**TEAM LOSI**  
**RACING**

## Welcome Team Losi XXX-T CR Owner!

Thank you for selecting the XXX-T CR as your new racing truck. The XXX-T CR has already distinguished itself as a top caliber racing chassis and as you will see, we have made every effort to produce a kit that is not only the most competitive but also easy to build and maintain. The simple bag-by-bag assembly sequence and easily followed instructions and drawings combined with Team Losi's world famous quality fitting parts will make building the XXX-T CR a most enjoyable project.

Before you open the first bag, or start assembly, please take a moment to read through the following instructions. This will familiarize you with the various parts, assembly tips, and descriptions as well as the tools needed. Taking an extra moment before starting can save a good deal of time and assure proper assembly.

Good luck and good racing,  
Team Losi Racing

### XXX-CR COMPLETED KIT SPECIFICATIONS

Overall Chassis Length: 16.4in (416mm)	Wheelbase: 11.25in (286mm)	*Front Track Width: 12.725in (323mm)
Overall Length w/Tires: 17in (431mm)	*Overall Height: 5.5in (139mm)	*Rear Track Width: 12.725in (323mm)

*Note: Final kit weight will vary depending on accessories used.*

*\*All measurements taken at ride height (23mm).*

*Table 1: XXX-T CR Completed Kit Specifications.*

### Kit/Manual Organization:

The kit is composed of different bags marked A through F. Each bag contains all of the parts necessary to complete a particular section of the kit. Some of these bags have sub-assembly bags within them. It is essential that you open only one bag at a time and follow the correct assembly sequence, otherwise you may face difficulties in finding the correct part. It is helpful to read through the instructions for an entire bag prior to beginning assembly. Next to each of the step numbers is a check box. At the completion of each step, place a check in this box so that if you must stop and come back to the assembly, you will be able to pick up where you left off.

For your convenience, an actual-size Hardware Identification Guide is included as a fold-out page at the back of this manual. Hardware that is not easily differentiable in each step is called out with an icon which contains a small picture of the part genre (referenced on the Hardware Identification Guide), the quantity of that part required for what is **shown** in the step, and the size or name of that part. To check a part, hold it against the silhouette until the correct part is identified. Associated with each of these parts, in the Hardware Identification Guide, is a LOSA-Number which is used when ordering replacement parts for your XXX-T CR. In some cases, extra hardware has been supplied for parts that may be easy to lose.

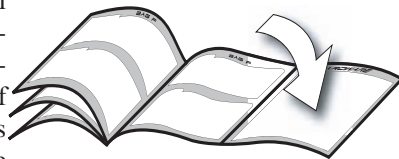

Components used in each step are identified by their relative LOSA-Number and the component's name. With the exception of a few parts, these are not referenced in the Hardware Identification Guide.

The molded parts in Team Losi Racing kits are manufactured to demanding tolerances. When screws are tightened to the point of being snug, the parts are held firmly in place. For this reason, **it is very important that screws not be overtightened in any of the plastic parts.**

In some steps there will be a filled black circle with a white number. These indicate the specific order by which assembly must occur. In cases where steps are repeated (front/rear or left/right) these numbers may be omitted. Please note that these numbers will not call out every sub-step required for the step's assembly procedures, they will only highlight the critical order required for assembly.

In each step, there are specific "Detail Icons" (shaped like a stop sign) that call out critical precautions or assembly tips for the process. There is a reference key that describes the meaning of each of the icons located on the fold-out Hardware Identification Guide at the back of this manual.

To ensure that parts are not lost during construction, it is recommended that you work over a towel or mat to prevent parts from rolling away.

### **IMPORTANT SAFETY NOTES:**

1. Select an area for assembly that is away from the reach of small children. *Some parts in this kit are small and can be swallowed by children, causing choking and possible internal injury; PLEASE USE CAUTION!*
2. The shock fluid and greases supplied should be kept out of children's reach. *They are not intended for human consumption!*
3. Exercise care when using any hand tools, sharp instruments, or power tools during construction.
4. Carefully read all manufacturer's warnings and cautions *for any chemicals, glues, or paints that may be used for assembly and*

## TOOLS REQUIRED FOR ASSEMBLY

Team Losi has supplied all necessary Allen wrenches and a special wrench that is needed for assembly and adjustments. The following common tools will also be required: Needle-nose pliers, regular pliers, hobby knife, scissors or other body cutting/trimming tools, and a soldering iron may be necessary for radio installation. 3/16", 1/4", 5/16", and 11/32" nut drivers are optional.

## RADIO/ELECTRONICS

A suggested radio layout is provided in this manual. Your high performance R/C center should be consulted regarding specific questions pertaining to radio/electrical equipment.

## HARDWARE IDENTIFICATION

When in question, use the Hardware Identification Guide at the back of this manual.

- For screws, the prefix number designates the thread size and number of threads per inch (i.e., 4-40 is a #4 size thread with 40 threads per inch). The second number, or fraction, designates the length of the screw. For cap head and button head screws, this number refers to the length of the threaded portion of the screw. For flat head and set screws, this number refers to the overall length of the screw.
- Bearings and bushings are referenced by the inside diameter (I.D.) x outside diameter (O.D.).
- Shafts and pins are designated by type (Roll, Solid) and referenced by diameter x length.
- Washers, Spacers and Shims are described by inside diameter or the screw size that will pass through the inside diameter x the thickness or by their designated application (i.e., Ball Stud washer is primarily used under a Ball Stud).
- Retaining Clips are sized by the shaft diameter that they attach to or by type (Body). The Hardware Icon associated with E/C-Clips only designates the part genre of clips, not the actual part.
- Nuts come in four types, Non-Flanged, Flanged (F), Plain, and Locking (L) (designated on the Hardware Icons). The prefix number designates the thread size and number of threads per inch. The second number, or fraction, designates the size of the hex. For example, L 4-40 x 1/4" designates a Lock nut that will thread onto a 4-40 screw using a 1/4" nut driver.
- Ball studs are described by the length of the neck between the base and the bottom of the ball (i.e., standard, short) and the length of the threaded portion.

# TABLE OF CONTENTS

## SECTIONS

## TABLES

1. INTRODUCTION.....	<i>i</i>
Kit/Manual Organization .....	<i>i</i>
Important Safety Notes .....	<i>i</i>
Tools Required for Assembly.....	<i>ii</i>
Radio/Electronics.....	<i>ii</i>
Hardware Identification .....	<i>ii</i>
2. Bag A: Front Clip .....	1-3
3. Bag B: Chassis.....	4-5
4. Bag C: Rear Clip .....	6-8
5. Bag D: Transmission .....	9-11
6. Bag E: Shocks .....	12-13
7. Bag F: Final Chassis/Electronics.....	14-18
8. Checklist Before Your First Run .....	19
9. Setup Guide .....	20-23
10. Blank XXX-T CR Setup Sheet .....	24
11. Hardware Identification Guide.....	25
12. Filled-out XXX-T CR Kit Setup Sheet .....	26

<b>Table 1:</b> XXX-T CR Completed Kit Specifications.....	<i>i</i>
<b>Table 2:</b> Servo Installation .....	4
<b>Table 3:</b> Motor Gearing.....	20



**STEP A-01**

**Steering Assembly**

Tighten the 6-40 x 5/16" Nut all the way down and then loosen it 2 full turns.

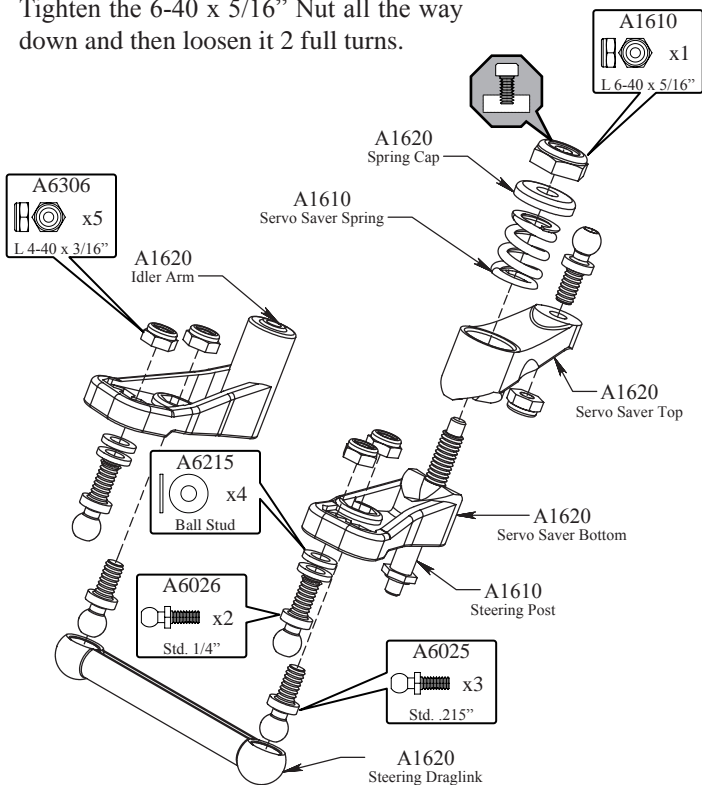

**STEP A-02**

**Kickplate Assembly**

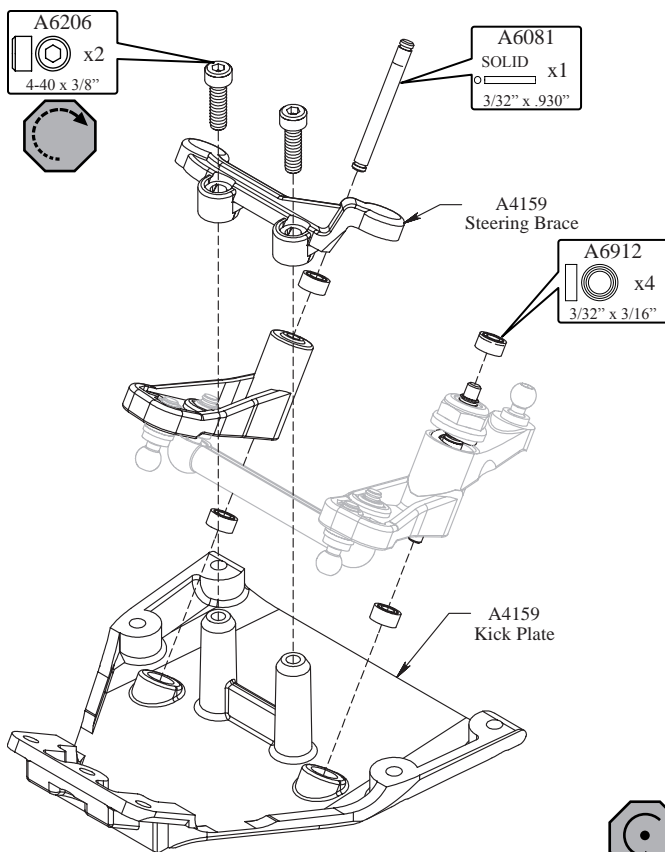

**STEP A-03**

**Front Suspension Assembly**

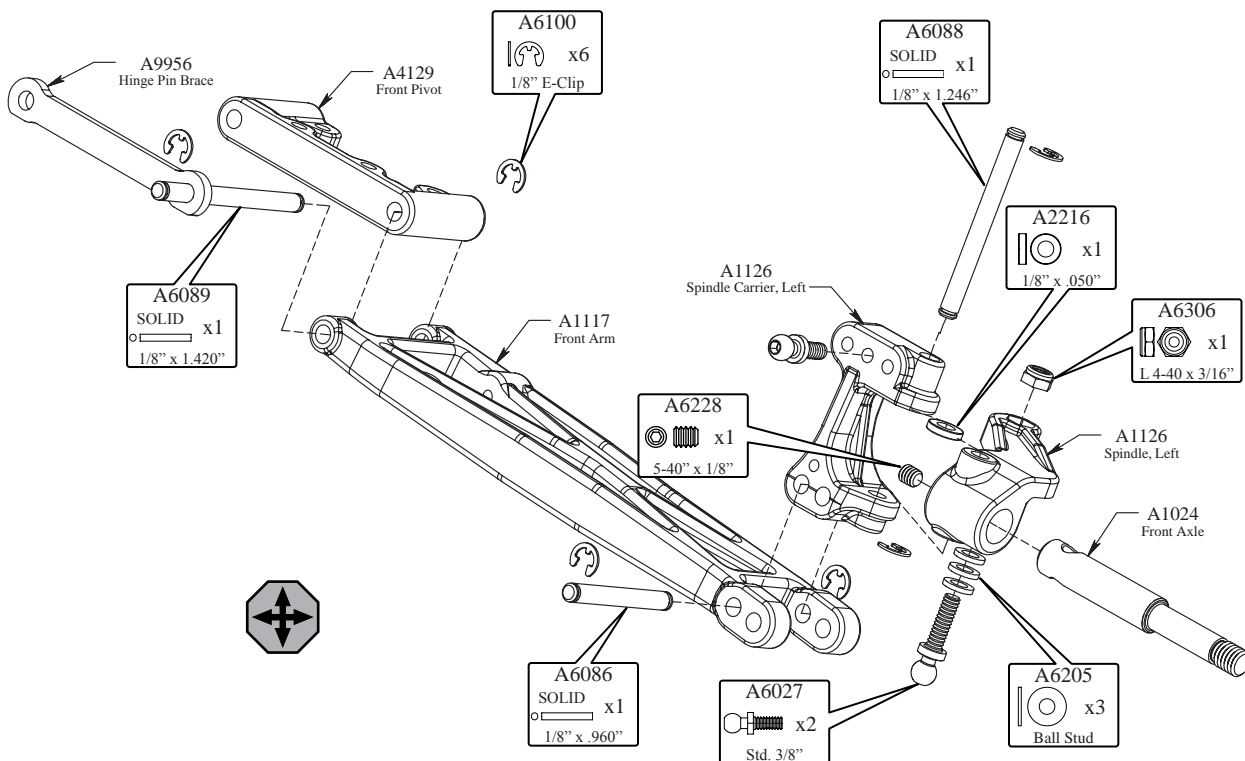

**STEP A-04**

*Front Bulkhead Assembly*

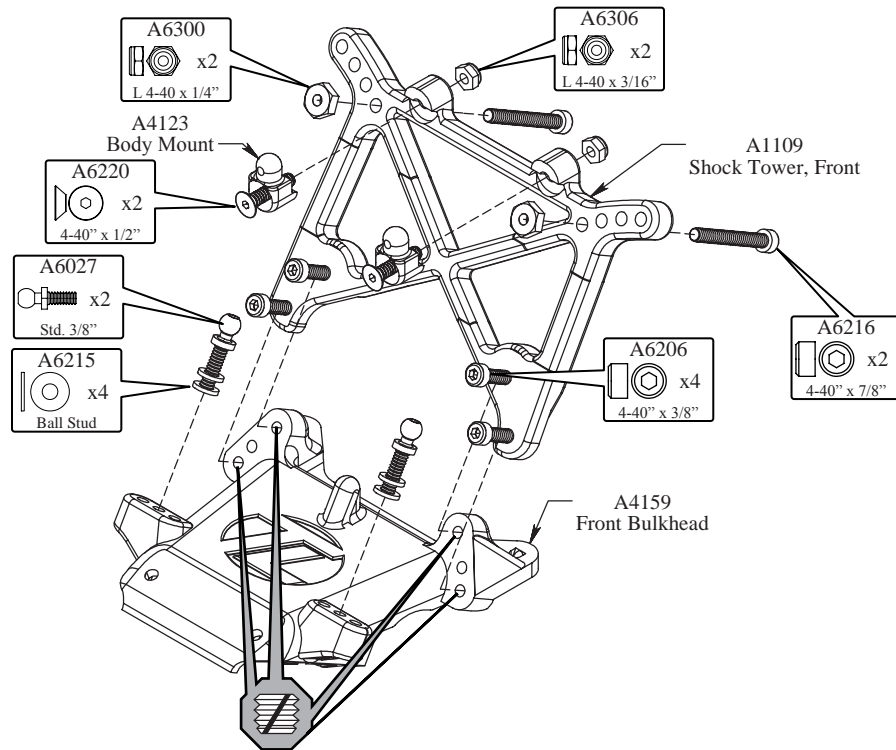

**STEP A-05**

*Front Clip Assembly*

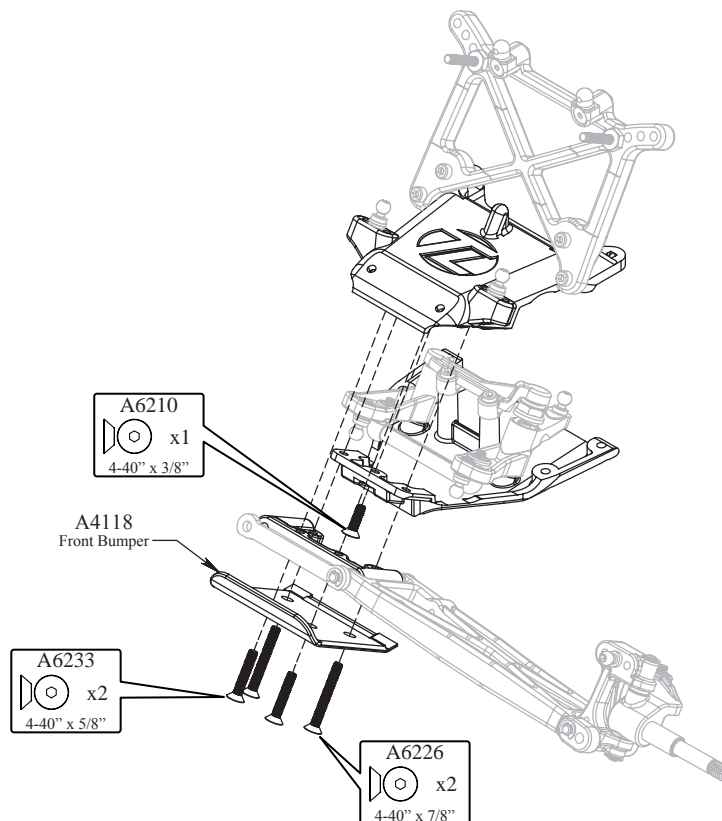

**STEP A-06**

**Tierod Assembly and Installation**

- Use the Team Losi flat wrench to hold the Turnbuckle while installing the Ball Cups.
- Be sure to install the assembled Tierod onto the truck with the groove (next to the center square section) on the driver's left side for easier adjustment later.

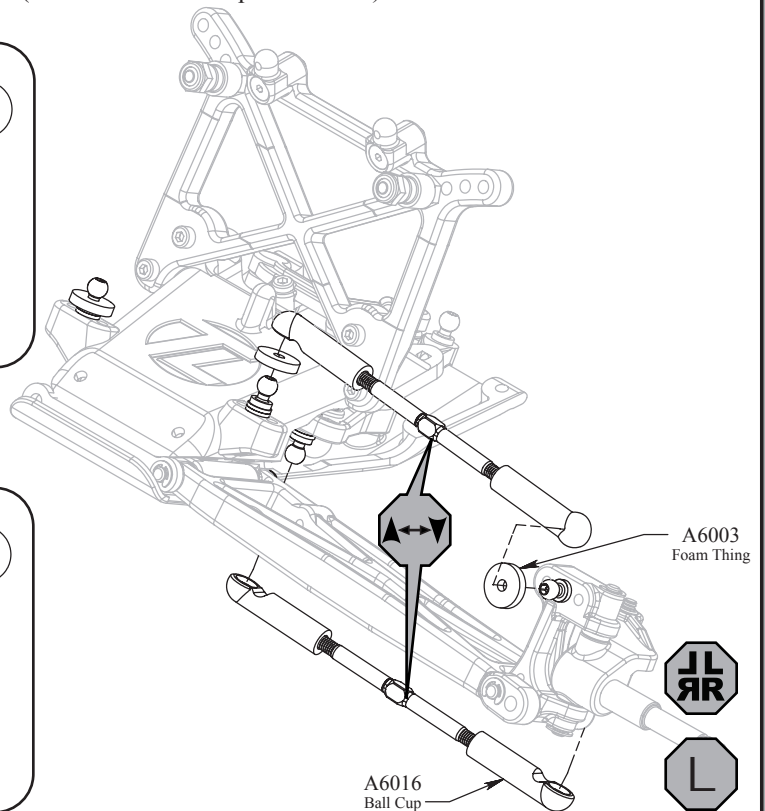
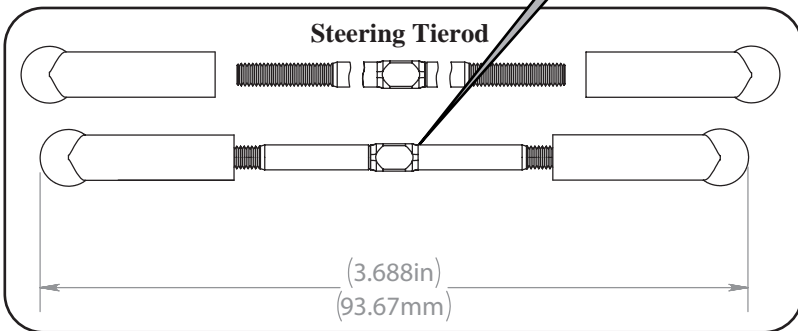
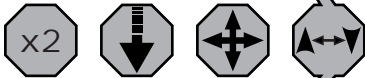
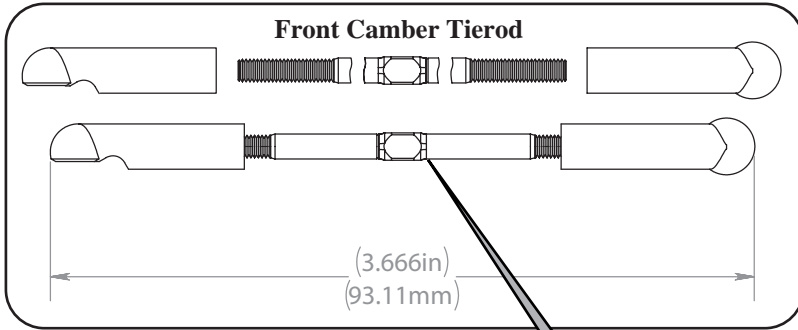

**STEP A-07**

**Completed Front Clip Assembly**

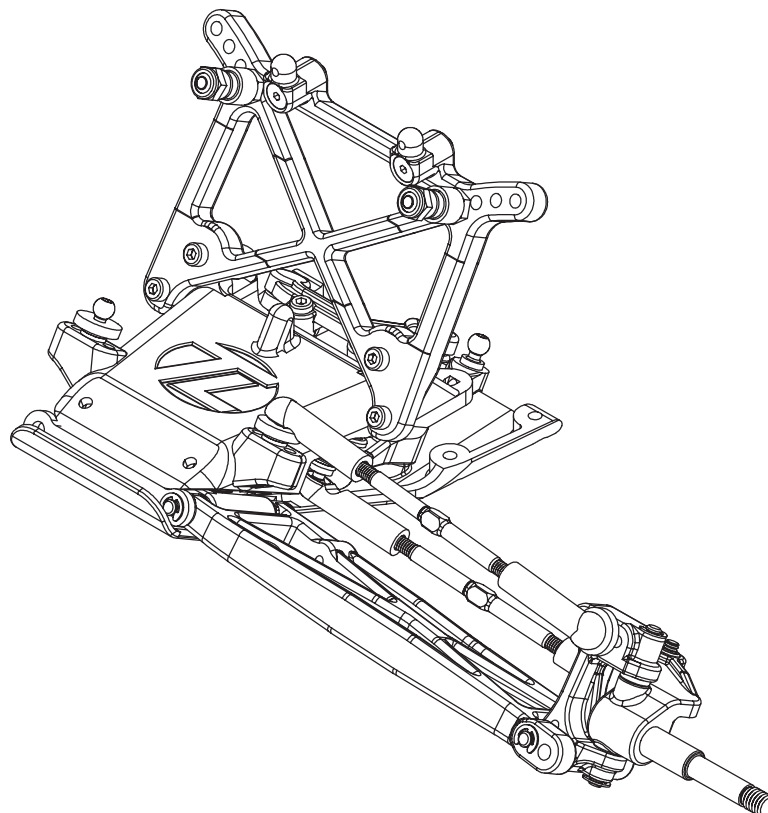

## STEP B-01

### Servo Assembly

Servo Manufacturer, Make/Model		Mount Position	Servo Horn
JR	All (DZ9000T/S DOES NOT FIT)	1	23T
Airtronics	94357Z, 94358Z, 94649Z, 94360Z, 94452Z, 94758Z, 94737Z, 94738Z	3	23T
	94102Z, 94112Z	1	
Hitec	All	1	24T
Futaba	All (S9102 DOES NOT FIT)	2	25T
KO	PDS-2123, 2344, 2363, 2365, 2366	2	23T
		1	

Table 2: Servo assembly and installation.

- Ensure the servo gear is **centered** before attaching the Servo Horn. This is best accomplished by connecting the servo to the radio system and setting the trim to center.
- Install the Servo Mounts in the orientation corresponding to the numbered diagram to the above right and Table 2.
- **DO NOT** tighten the four 4-40 x 3/8" Cap Head Screws all the way, they must be tightened after assembly to the Chassis is complete to ensure proper alignment.

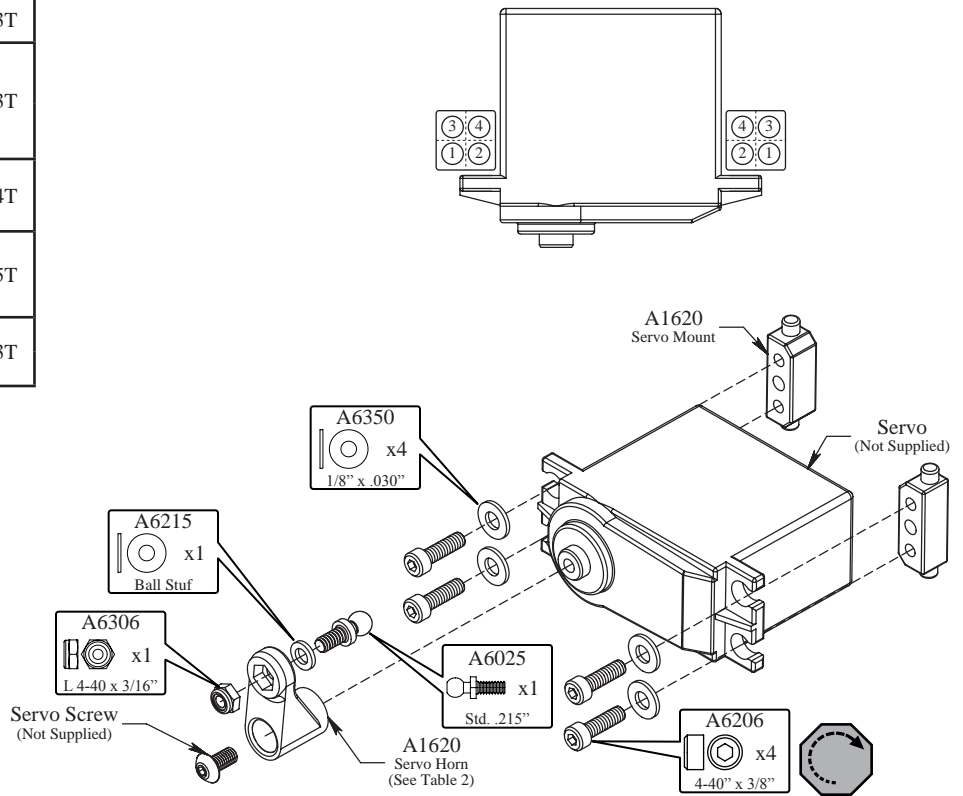

## STEP B-02

### Servo Installation

- First place the Servo into the Chassis and place the Chassis Stiffener on top to ensure the servo is centered in-between the Mounts and as low as possible. Remove and tighten the four 4-40 x 3/8" Cap Head Screws and continue with the installation.

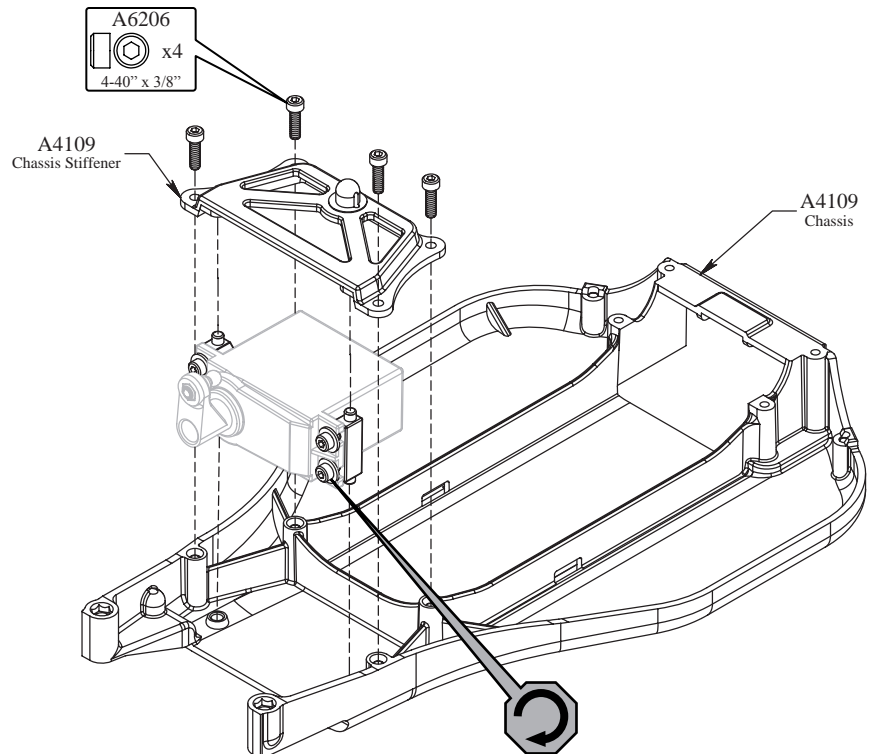

**STEP B-03**

*Chassis Assembly*

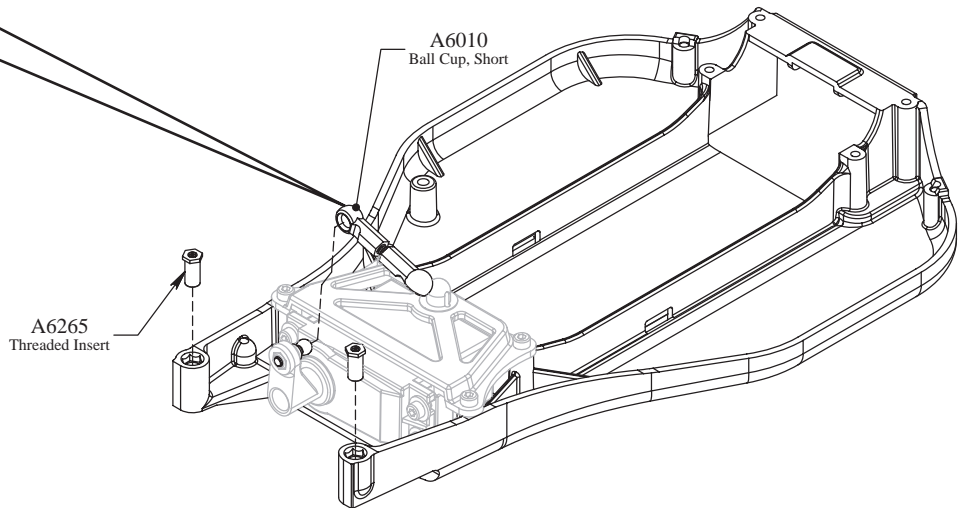
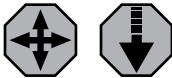
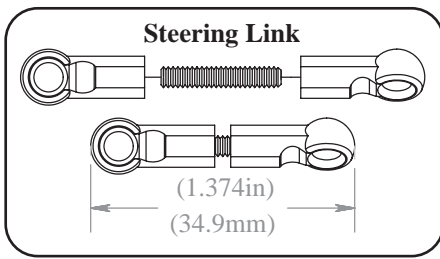

- The Steering Link length will vary depending on the brand and model of Servo used. This length is only a starting point and will most likely need to be adjusted in Step F-01.

**STEP B-04**

*Completed Chassis*

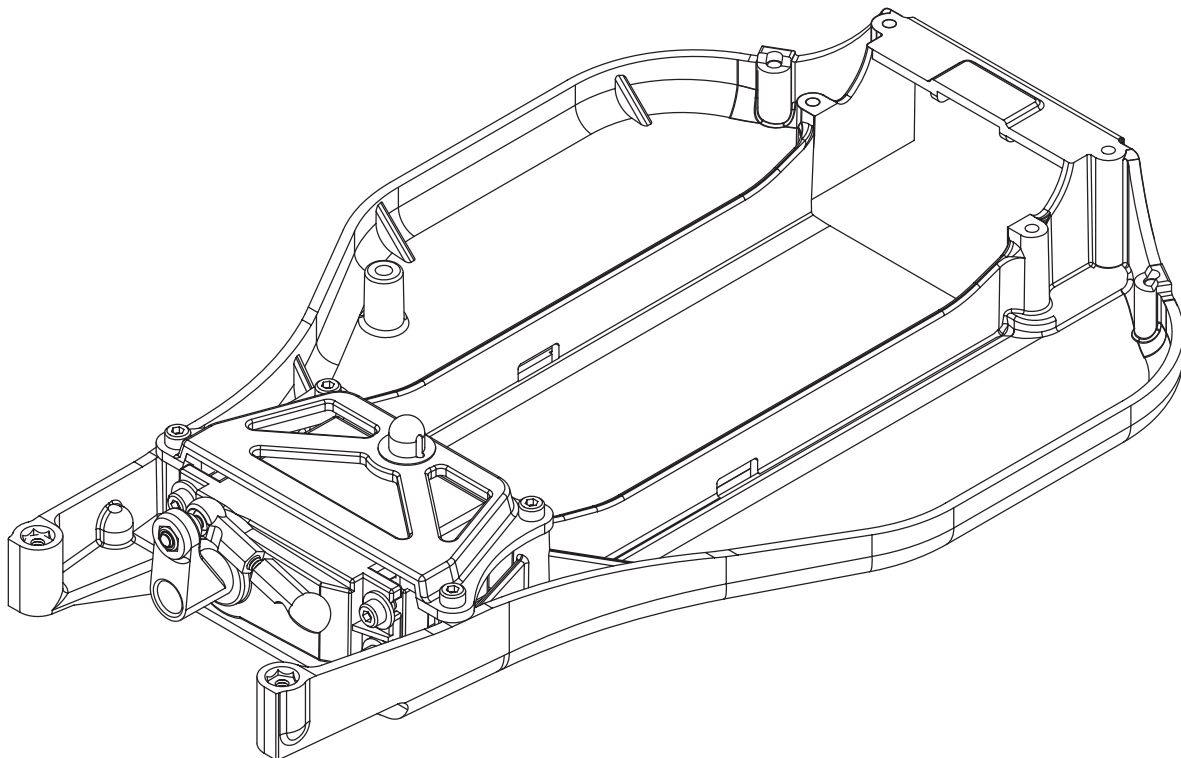



**STEP C-01**

*Dogbone Assembly*

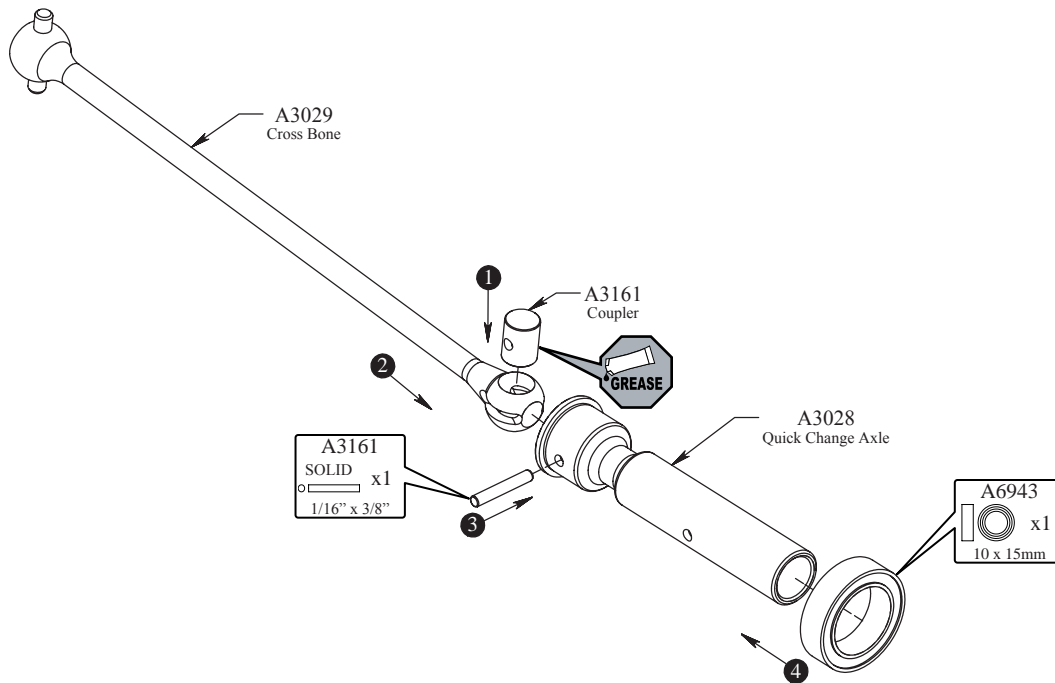

**STEP C-02**

*Rear Hub Carrier Assembly*

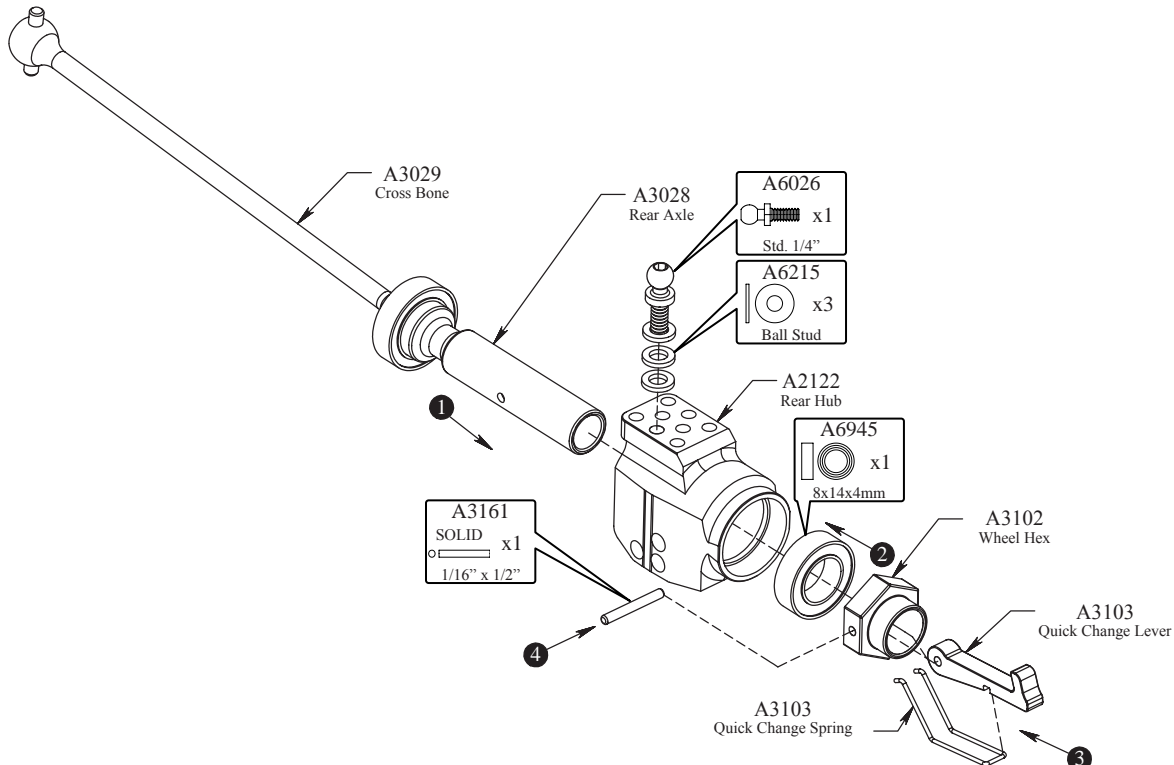

**STEP C-03**

**Rear Suspension Assembly**

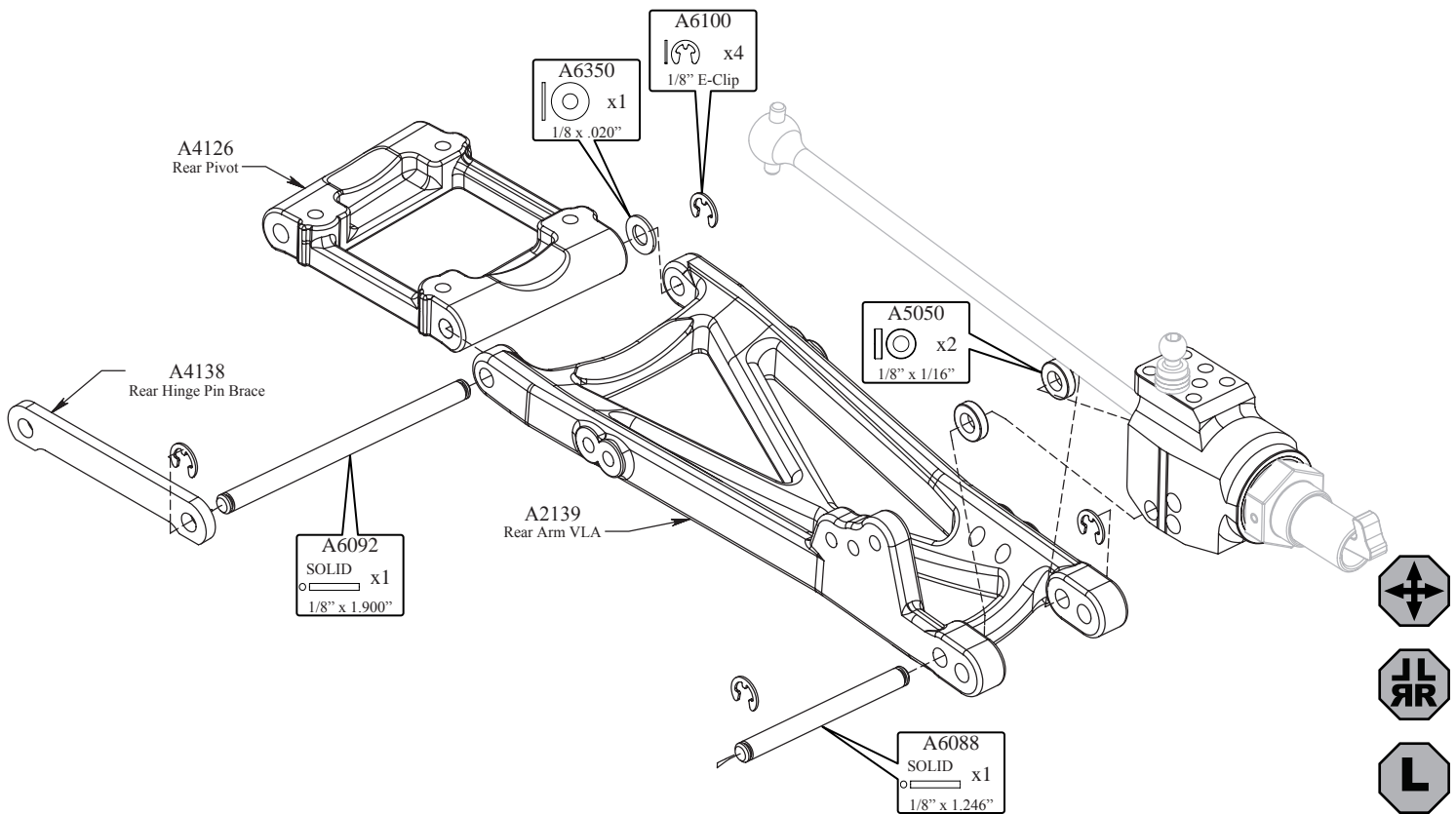

**STEP C-04**

**Rear Bulkhead Assembly**

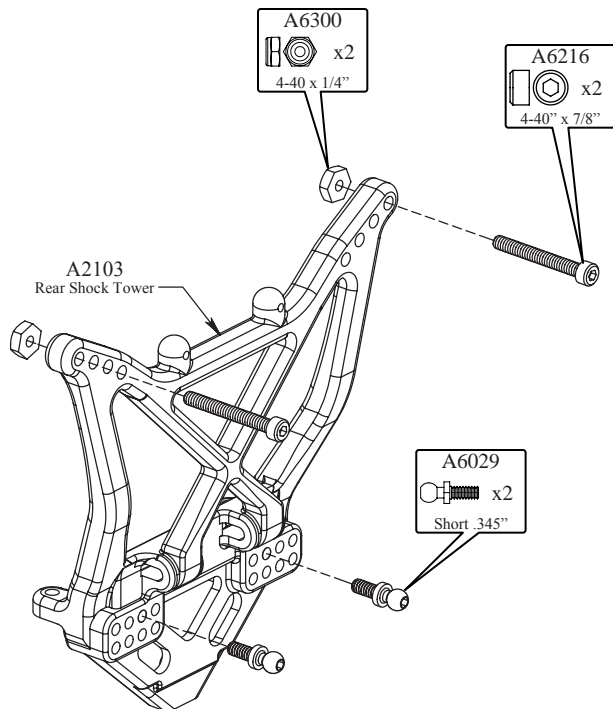

**STEP C-05**

**Rear Plate Assembly**

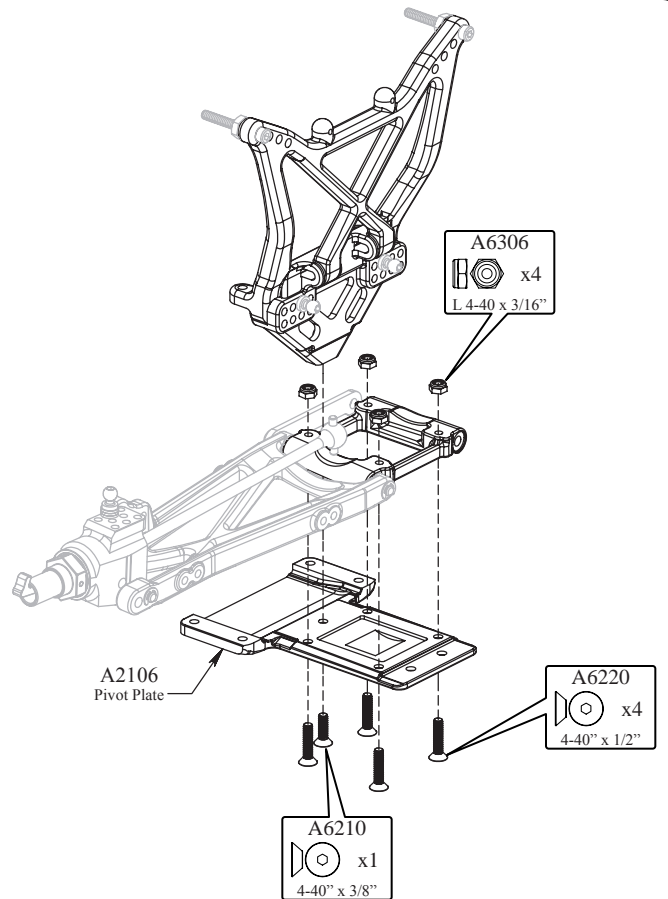

**STEP C-06**

*Tierod Assembly and Installation*

- Use the Team Losi flat wrench to hold the Turnbuckle while installing the Ball Cups.
- Be sure to install the assembled Tierod onto the car with the groove (next to the center square section) on the driver's left side for easier adjustment later.

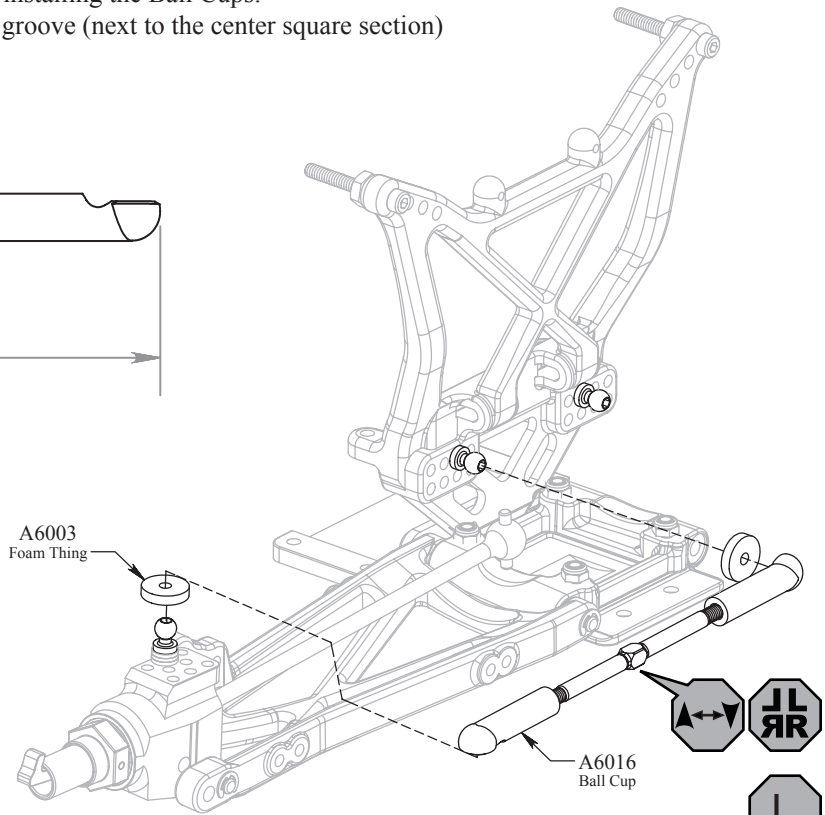
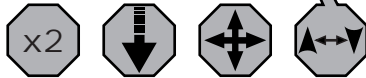
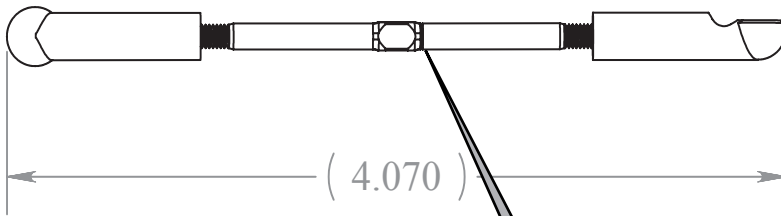

**STEP C-07**

*Completed Rear Suspension*

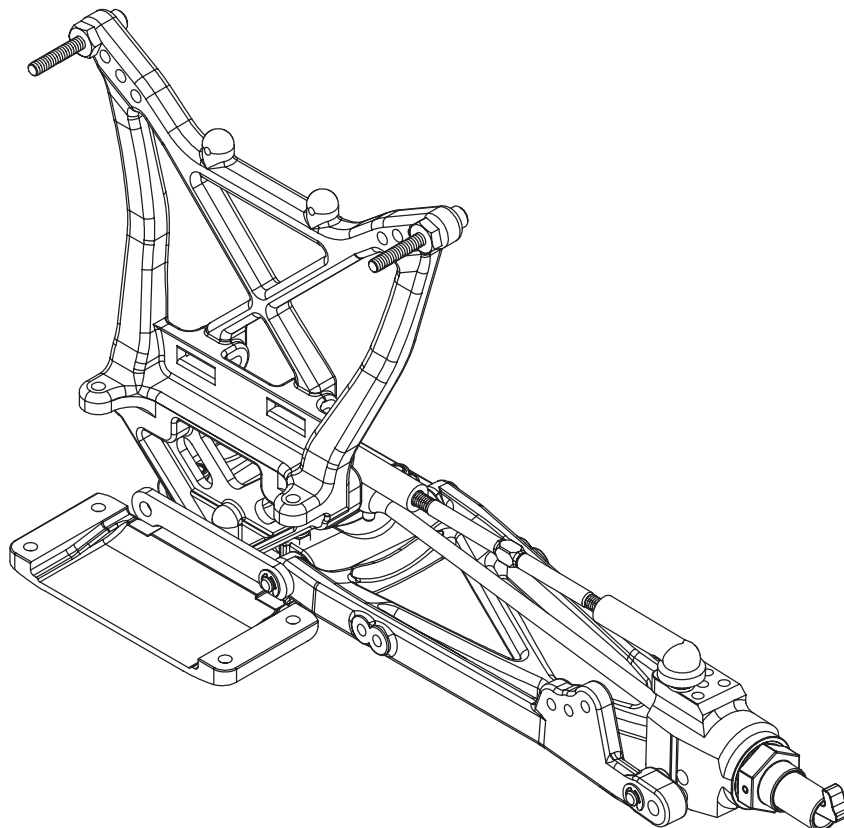

**STEP D-01**

**Differential Assembly**

- Apply a small amount of Clear Diff Grease to both Diff Outdrives and the Diff Ring Shims before installing the Diff Rings.
- Apply enough Clear Diff Grease to the top side of the Diff Rings, or to both sides of recessed Ball section in the Diff Gear (after Diff Balls are installed) to cover the Diff Balls when the Diff is assembled.
- Assemble the Diff and tighten until some resistance is felt, see the Final Checklist and Setup Guide for final Diff adjustment procedures.

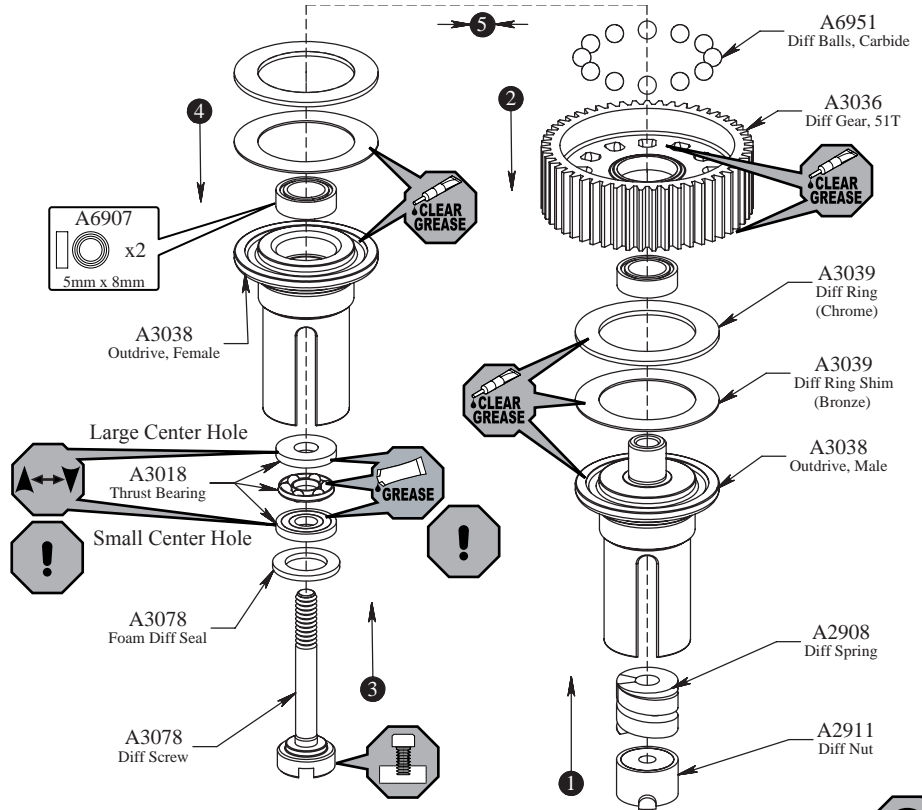

- The Diff Ring Shims are optional. If you choose not to use them (See Setup Guide), you must install the smaller Diff Shims on the outside of the Diff before installing the Diff into the Gearbox case.

**STEP D-02**

**Transmission Assembly**

- Install the Differential with the Diff Nut towards the Motor Plate.
- The Diff Ring Shims installed in the previous step are optional. If you choose not to use them (See Setup Guide), you must install two additional smaller Diff Shims on the outside of the Diff before installing the Diff into the Gearbox case. **NOTE, YOU MUST RUN AT LEAST TWO OF THESE SHIMS AS SHOWN.**

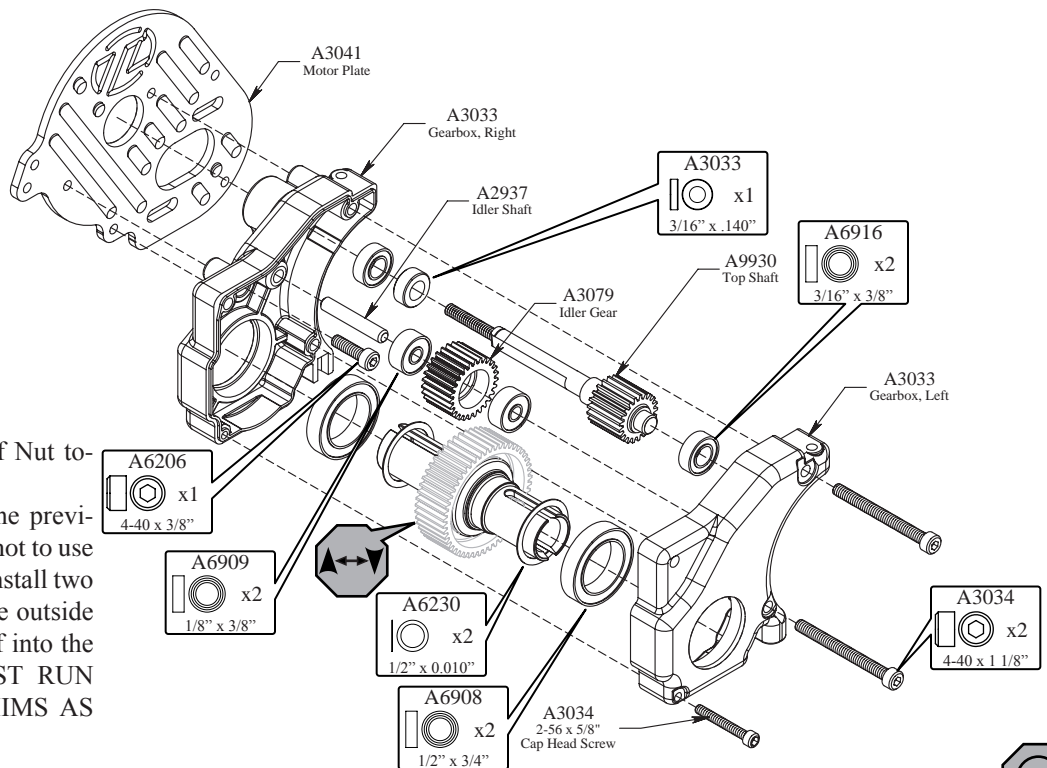

**STEP D-03**

**Slipper Clutch Installation**

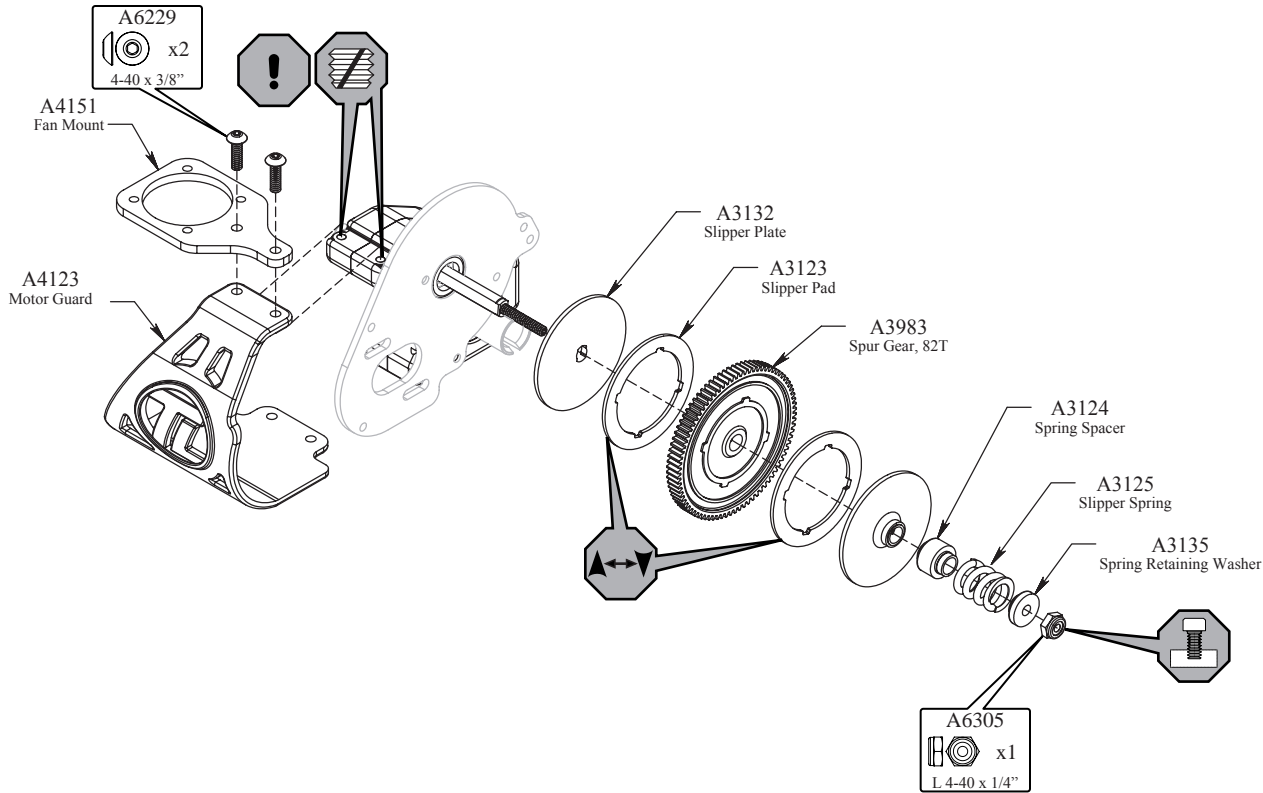

**STEP D-04**

**Motor Installation**

- When setting the gear mesh, leave a small amount of backlash for proper function. Too much backlash will cause failure, so be sure to check the mesh at different points in the rotation of the Spur Gear.

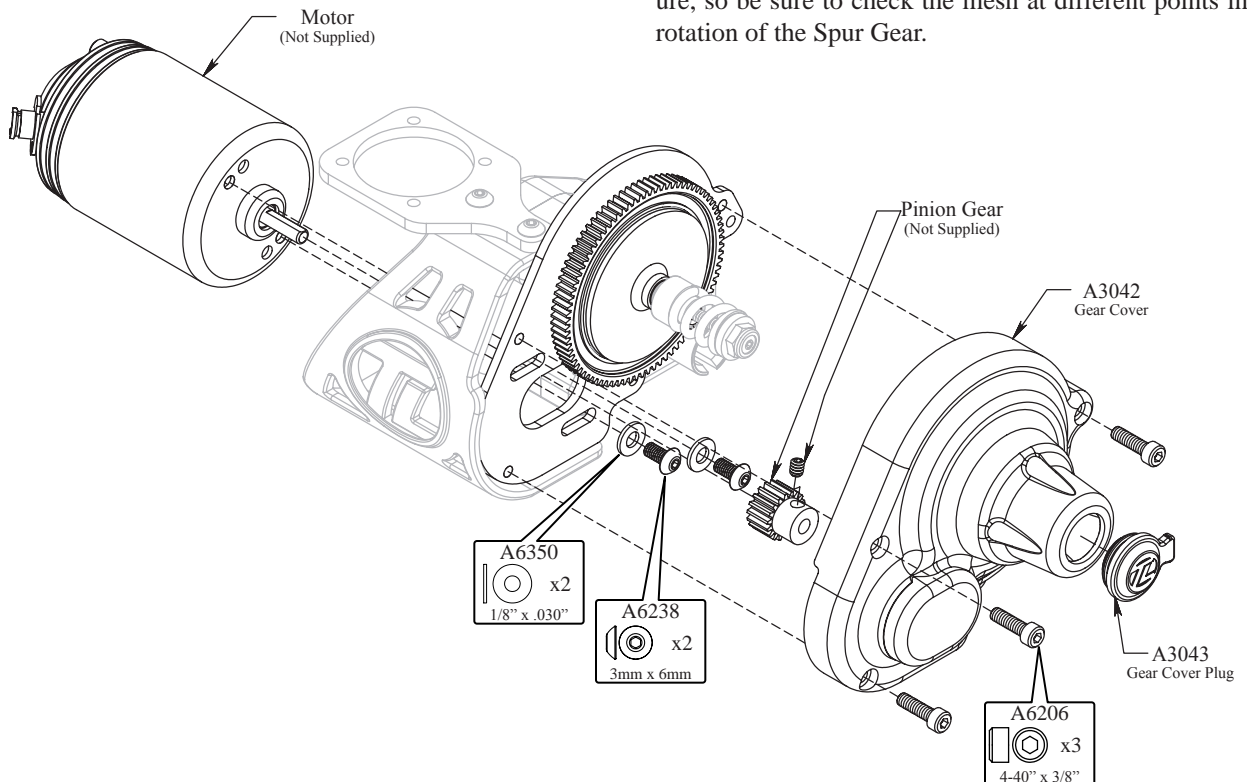

**STEP D-05**

*Transmission Installation*

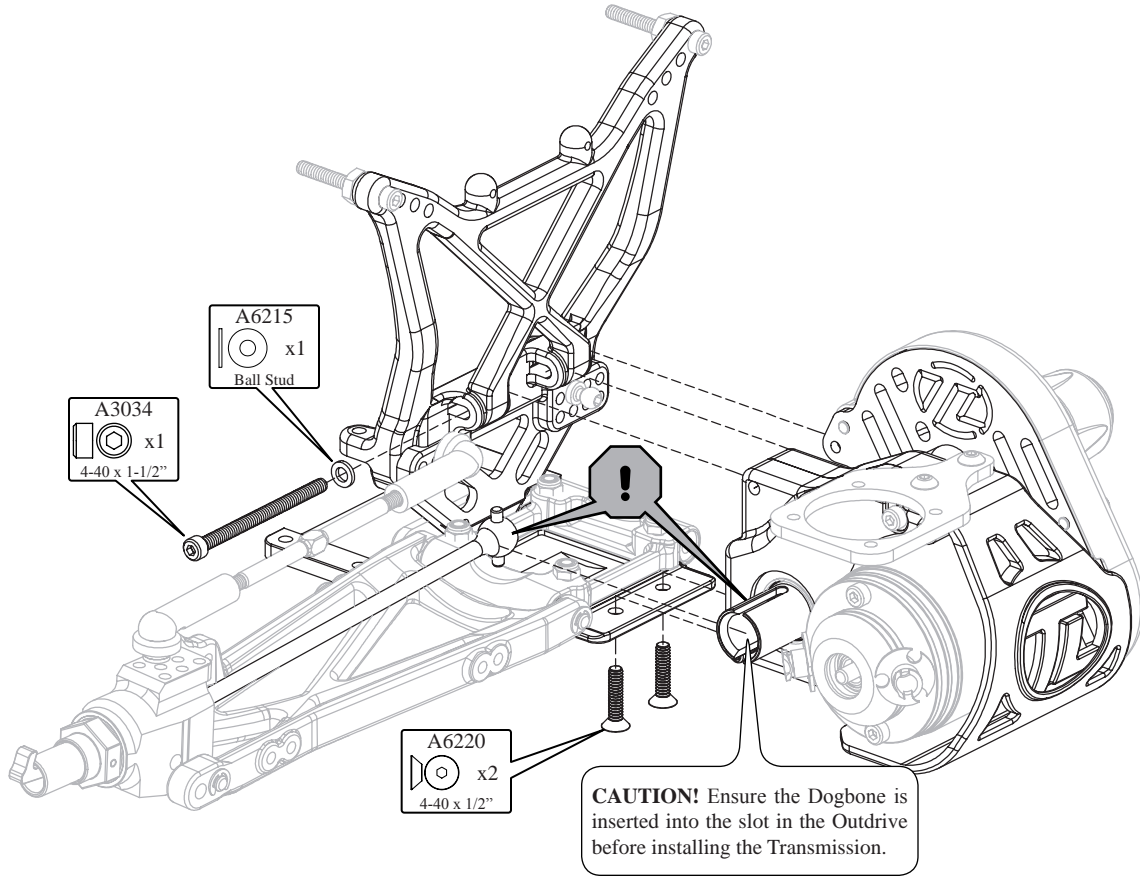

**STEP D-06**

*Completed Rear Clip Assembly*

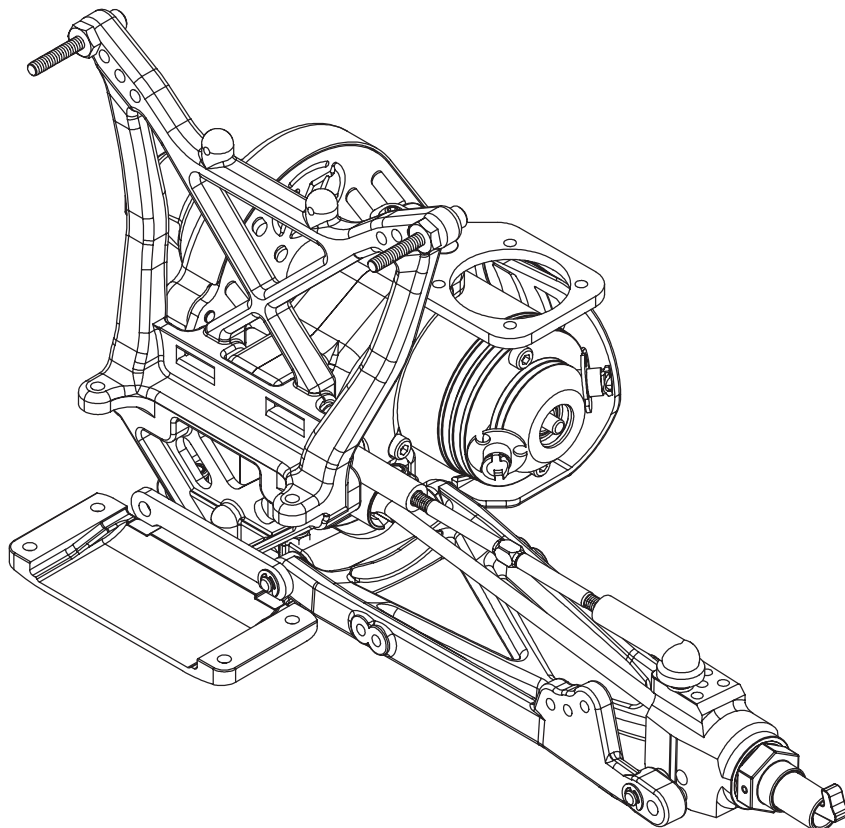

**STEP E-01**

**Shock Assembly**

- Match short front Shock Bodies with assembled short front Shock Shafts and long rear Shock Bodies to assembled long rear Shock Shafts.
- Holding the shock body inverted, fill the Shock Body with Shock Oil up to the bottom of the threads inside the Shock Body.
- Insert shaft assembly with cartridge against the shock piston.
- Slowly tighten the Cartridge until it bottoms against the Shock Body. Do not tighten all the way.
- Slowly push Shock Shaft assembly into the Shock Body. This will bleed the excess oil out of the Shock.
- Once the Shaft is pushed all the way down into the Shock Body, tighten the Shock Cartridge the rest of the way with a 7/16" wrench or a pair of pliers approximately 1/8th of a turn.
- There should be no air in the Shocks as you move the Shaft in and out of the Shock Body. If there is; you will need to add some Oil and repeat the bleed process. If the Shock does not compress all the way, the shock has too much Oil. Simply loosen the Cartridge about 1/4 turn and push the Shaft into the Body and retighten the Cartridge.

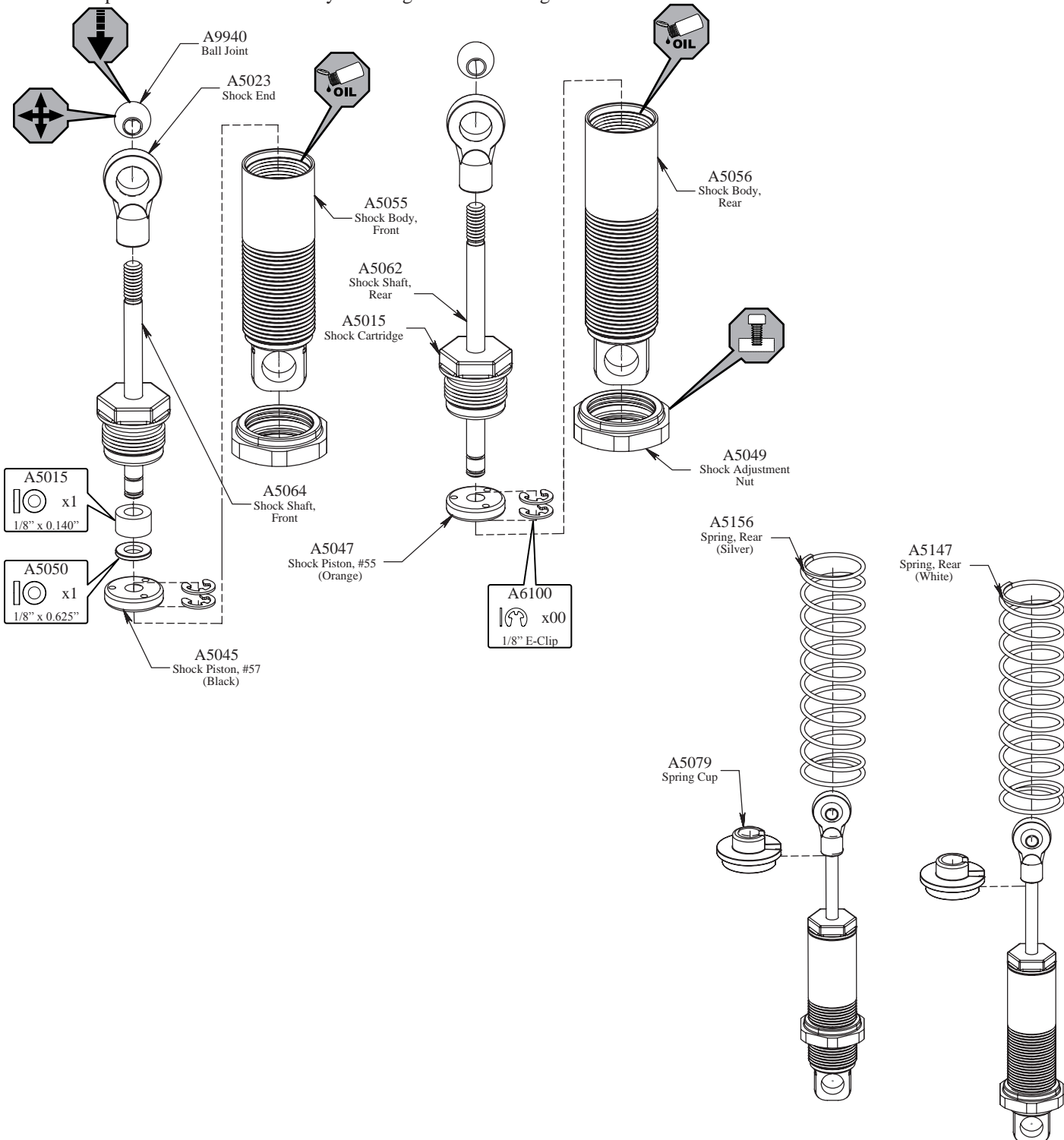

**STEP E-02**

*Front Shock Installation*

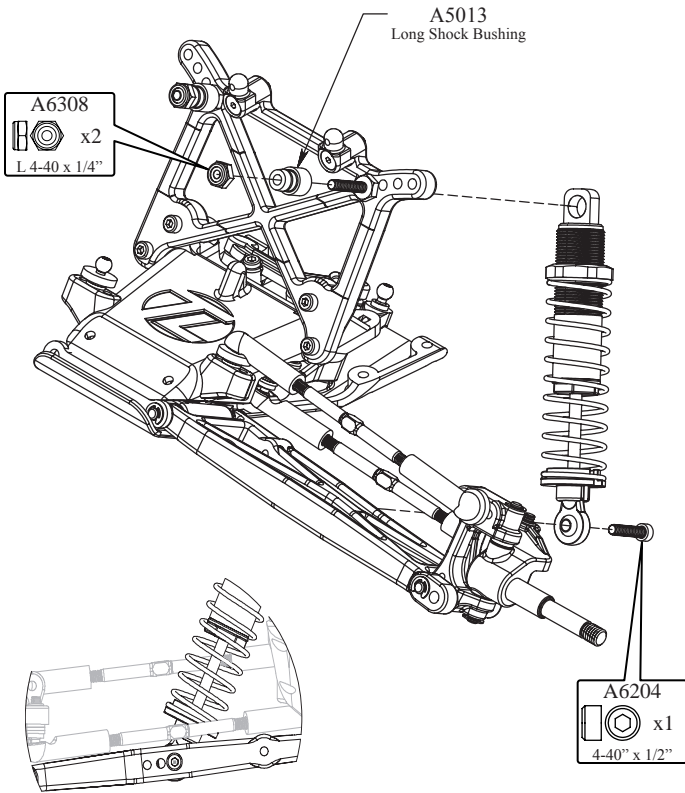

**STEP E-03**

*Rear Shock Installation*

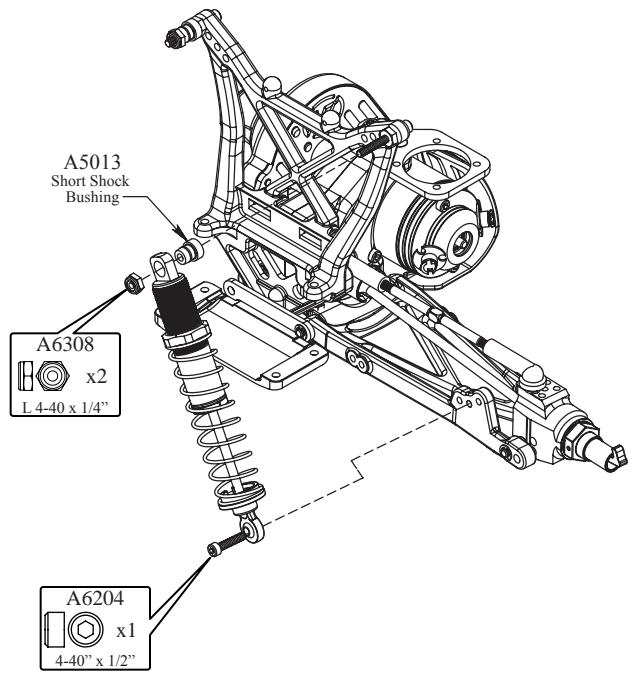

**STEP E-04**

*Completed Front and Rear Clips*

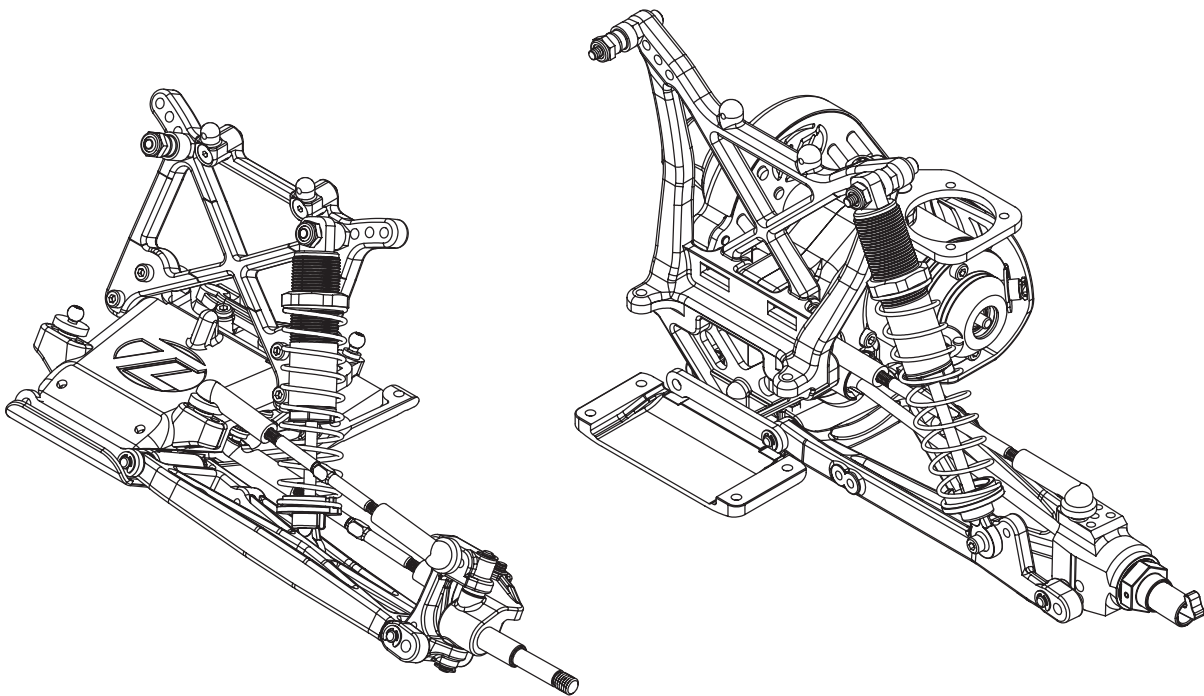



**STEP F-01**

**Front and Rear Clip Installation**

- The Servo Link installed in Step B-03 was set to an approximate length. The correct length will vary depending on the type of servo used, the radio settings, and the Servo Horn.
- It may be necessary to adjust this length, after all radio gear is installed and the servo is centered properly, to obtain the maximum steering throw and have the Steering Bellcranks centered without having extreme trim settings on the radio.

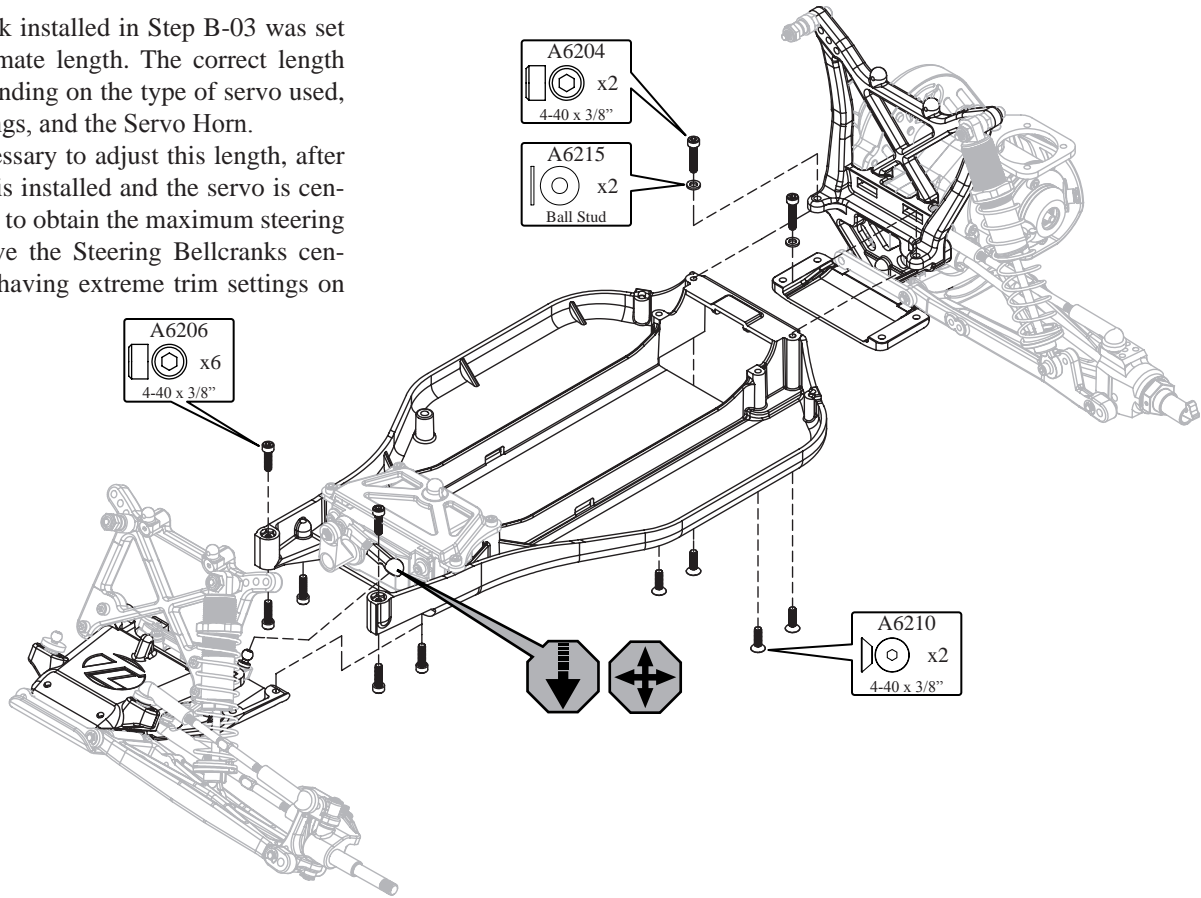

**STEP F-02**

**Speed Control Installation**

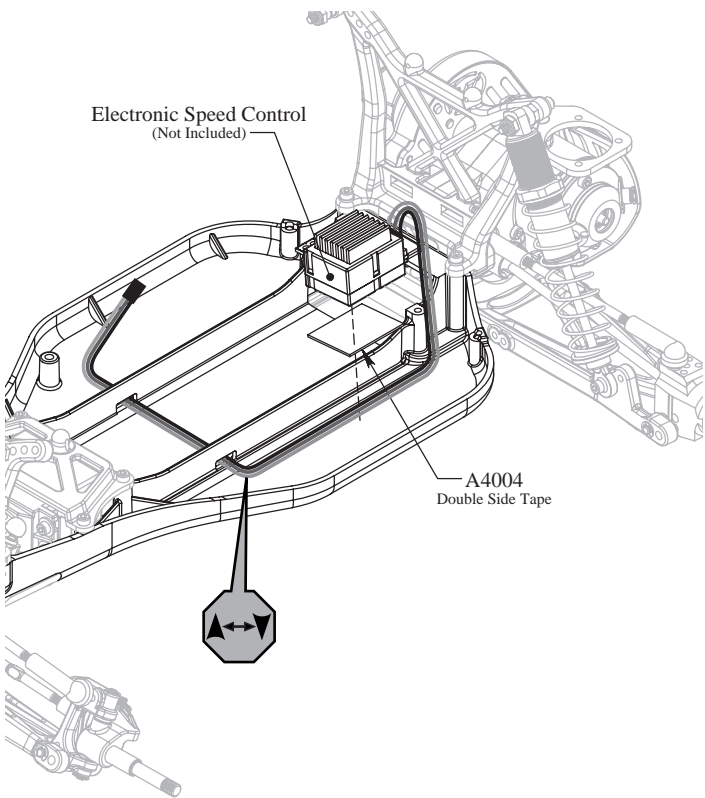

**STEP F-03**

**Receiver Installation**

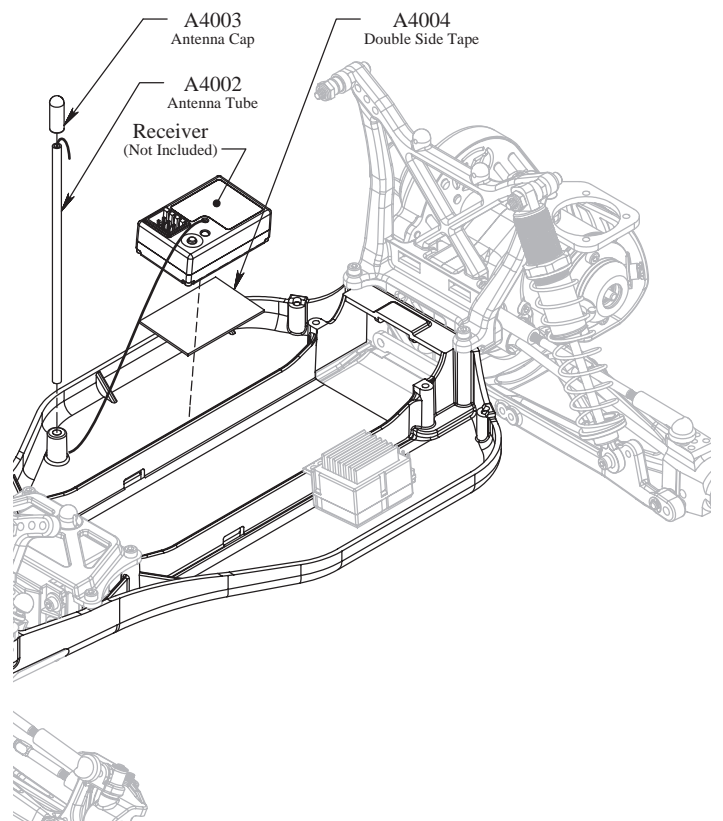

**STEP F-04**

**Battery Installation**

This configuration is for use with a stick type battery back.

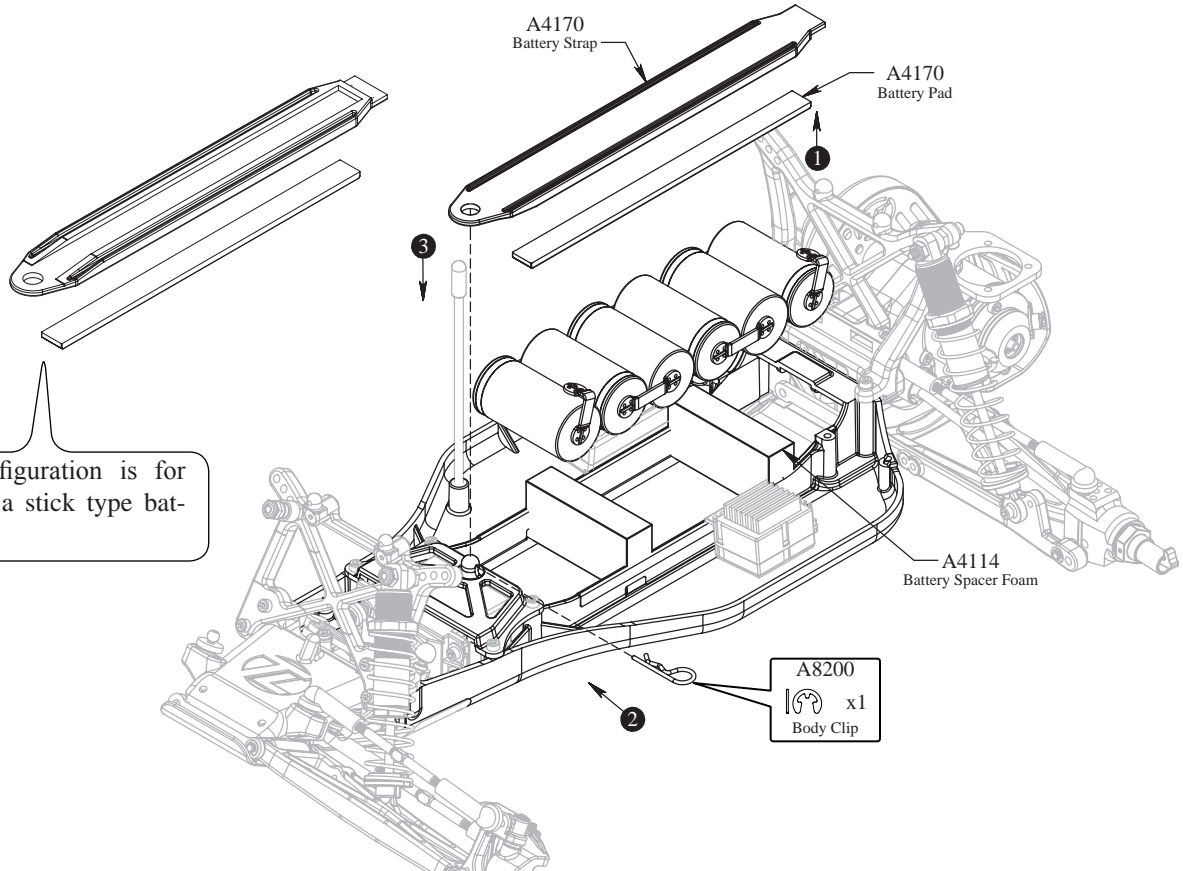

**STEP F-05**

**Tire Mounting**

- Using a pair of sharp scissors, carefully cut the inside corners of the Tire Foams away to allow for easier mounting on the Wheel as shown below.
- Ensure there is no flashing on the bead of the Tires, if so, trim it away to allow for easier mounting on the Wheel.

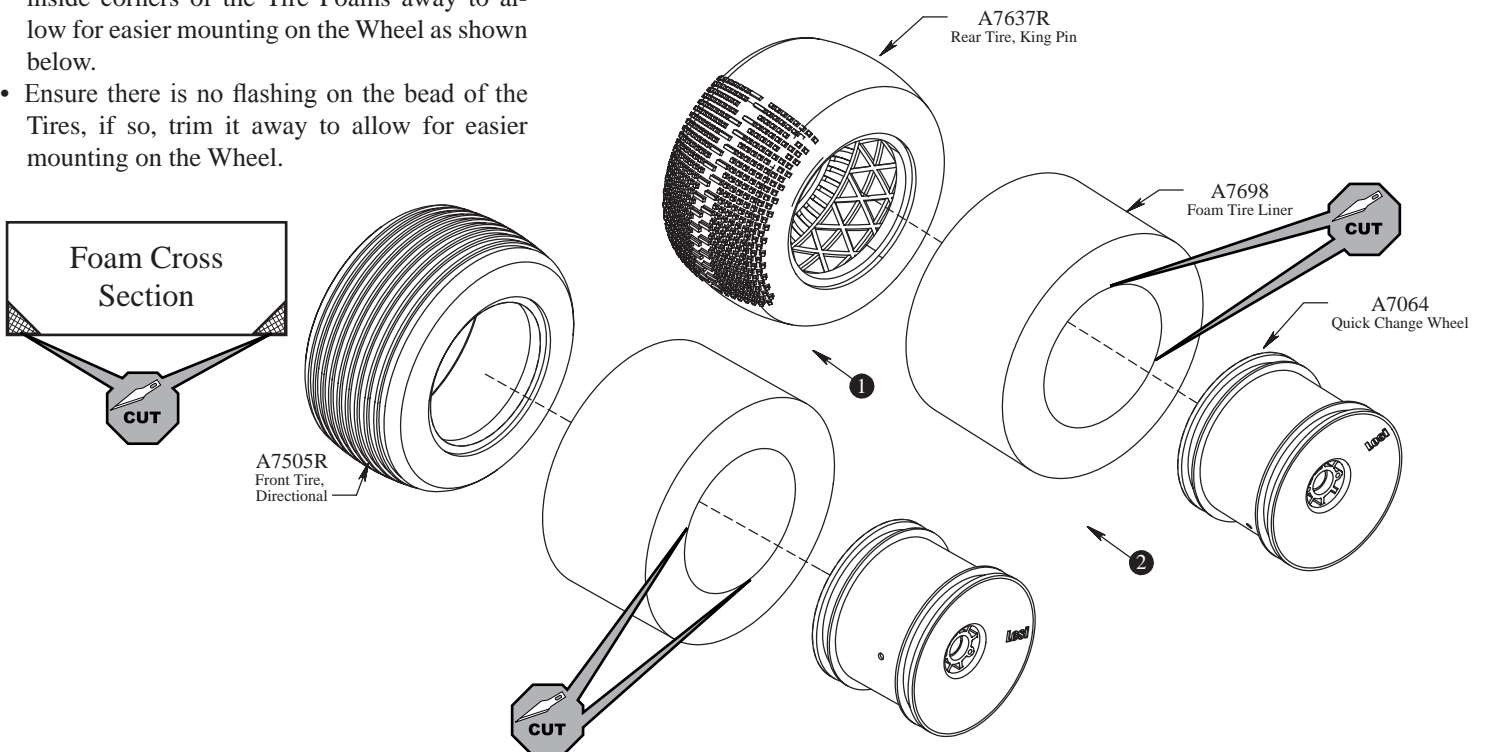

**STEP F-06**

*Tire Gluing*

- The Tires need to be glued to the wheels. This can be done by using a fast-curing super glue or cyanoacrylate glue (LOSA7880, LOSA7881), available at your local hobby shop. Install a Tire gluing rubber band around the outside of the Tire, in line with the bead to hold it onto the Wheel.
- Now slightly pull back the tire bead from the wheel and apply a thin bead of glue between the Tire bead and the Wheel all the way around, wait for this side to dry and do the same to the other side until the Tire is firmly adhered to the Wheel. Allow the glue to dry thoroughly before continuing.

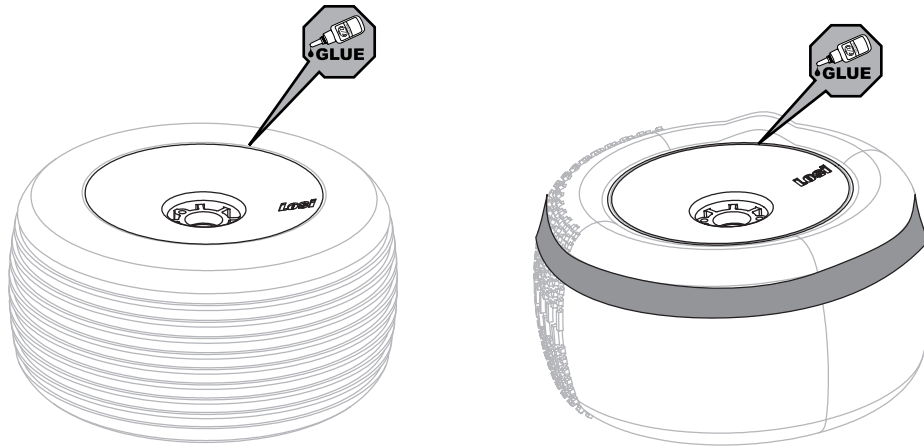

**STEP F-07**

*Tire Installation*

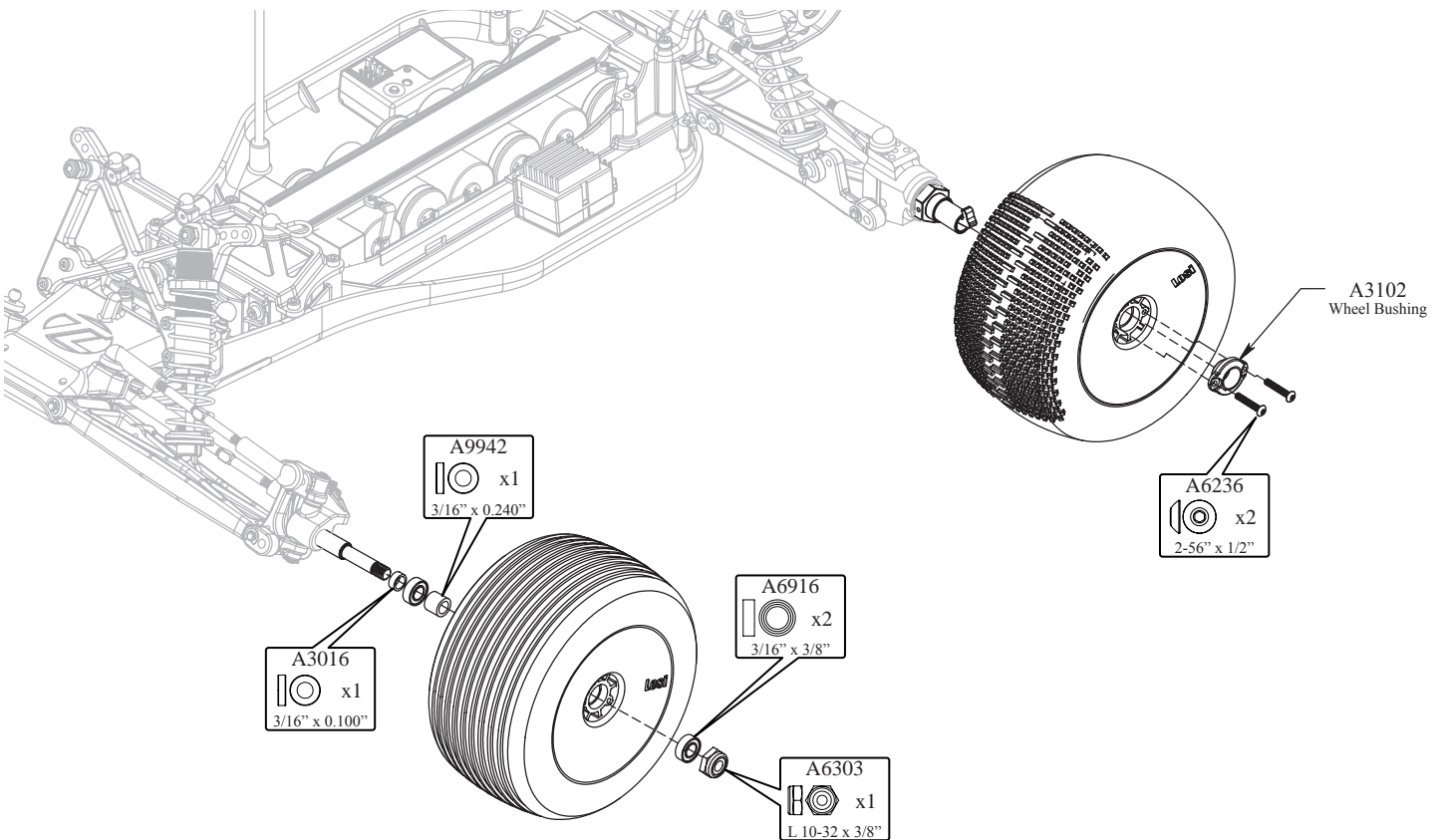

**STEP F-08**

*Body and Wing Painting*

**Painting:**

Prepare the Lexan® Body and Spoiler for painting by washing them thoroughly (inside and out) with warm water and liquid detergent. Dry both the Body and Wings with a clean, soft cloth. Use the supplied Window Masks to cover the windows from the inside. A high-quality masking tape should be used on the inside of the Body to mask off any stripes, panels, or designs that you wish to paint on the Body or Spoiler. Use acrylic lacquer or other paints recommended for Lexan® (polycarbonate). **(NOTE: LEXAN® R/C CAR BODIES ARE MEANT TO BE PAINTED FROM THE INSIDE!)** Apply paint to the inside of the Body and to the under-side of the Spoiler. Remove the masking tape for the next color and continue. Try to use darker colors first. If you use a dark color after a light color, apply a coat of white paint over the lighter color before applying the darker color, or if you are painting over white, coat it with silver. This will help prevent the darker color from bleeding through the lighter color.

**Mounting:**

After painting, trim the Body along the trim lines as shown below, emphasized by the dark shading in the figure below. There is an indented trim line around the Body which can be used as a guide for trimming. Make four 1/4"-diameter holes at the locations marked with dimples. There are two on the back of the Body, two on the front and one on the right side of the Body. These will be the Body mounting and Antenna holes.

Now trim the rear Spoiler along the trim line shown below. With the Spoiler painted and completely trimmed, cut a piece of Two Sided Tape approximately 3/8" wide and apply to the back side of the spoiler. Removed the backing from the tape and affix the Spoiler to the rear of the body as shown.

**Stickers:**

After the Body is mounted, **REMOVE THE PROTECTIVE FILM ON THE OUTER SURFACE**, now you can apply the stickers. Cut the stickers from the sticker sheet that you wish to apply to the Body or Wing. Before removing the protective backing, find the desired location. Remove the backing completely and reattach an edge of the sticker to the shiny side of the backing material. Using the rest of the backing material as a handle, position the sticker and press firmly into place to complete its application.

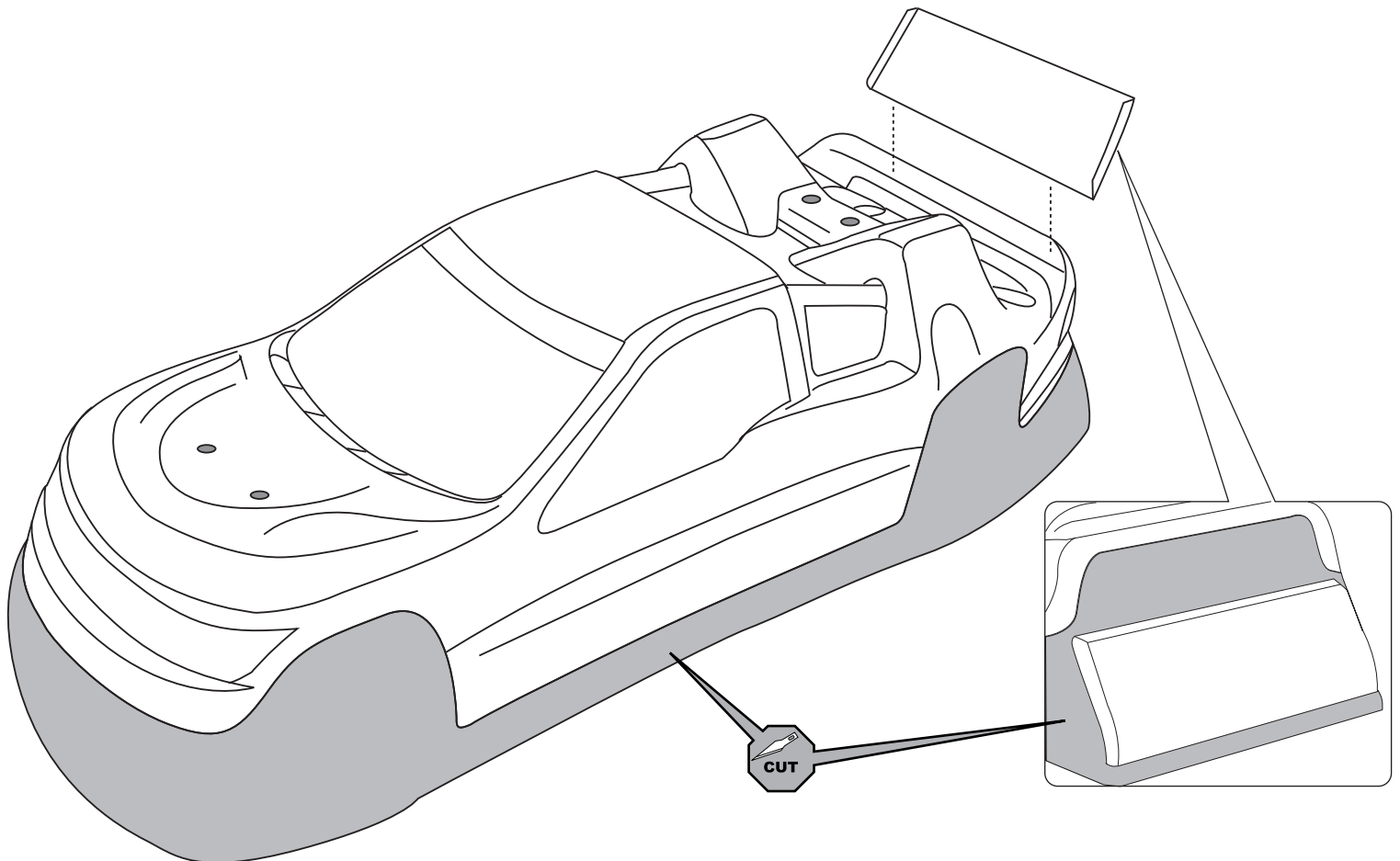

▣ **STEP F-09**

*Body and Wing Mounting*

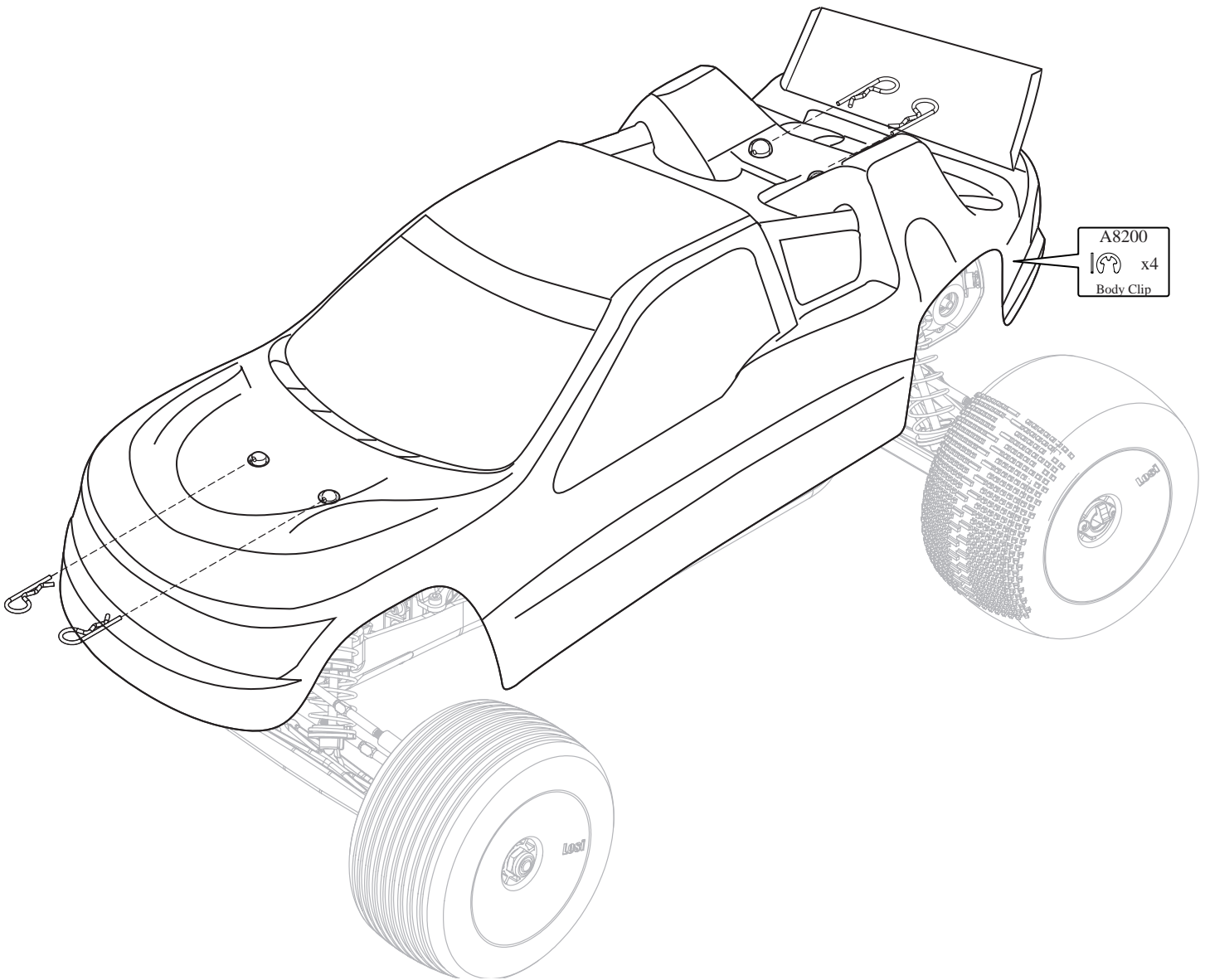

**BEFORE RUNNING YOUR NEW XXX-T CR OFF-ROAD RACING TRUCK** for the first time, you should run down the following checklist in order and complete the listed tasks. We're sure you're anxious to get out and run your new XXX-T CR now that its built, but please note that fine tuning of the initial setup is an essential part of building a high performance racing truck such as your new XXX-T CR. Following this simple Checklist and the Team Tips will help to make the first run with your new car much more enjoyable.

1. **Breaking in the Differential:**

While holding the chassis with **only** the left side tires firmly on the ground, give the truck about one quarter throttle, for 10 seconds. The right side tires should spin freely during this time. Repeat this with **only** the right side tires held firmly to the ground, allowing the left tires to spin. Feel the differential (diff) action and tighten slightly, if necessary. The differential should have a tight, thick feel when rotating it after final adjustment. **CAUTION! YOUR DIFFERENTIAL SHOULD NEVER BE ALLOWED TO SLIP WHEN RUNNING (A SLIPPING DIFFERENTIAL CREATES A "BARKING" SOUND). IF IT DOES, STOP IMMEDIATELY AND TIGHTEN TO PREVENT DAMAGE. SEE "DIFFERENTIAL ADJUSTMENT" AND "SLIPPER ADJUSTMENT" IN THE SETUP GUIDE.**

2. **Check for free suspension movement:**

All suspension arms and steering components should move freely. Any binds will cause the car to handle poorly.

3. **Set the ride height:**

Set the ride height on the rear so the dogbones are level (parallel) to the ground by adjusting the shock adjustment nuts, effectively increasing or decreasing pre-load on the springs. See the Setup Guide for additional information on ride height adjustment.

4. **Set the camber:**

Adjusting the camber tierod length changes the amount of camber. Using the Team Losi flat wrench to adjust the tierods once installed. Rotating the tierods towards the front end of the vehicle will shorten the length, increasing negative camber. Rotating the tierods towards the back of the truck will lengthen them, increasing negative camber. Set the front tires to have 1 degree of

negative camber and ensure that they are adjusted equally, left to right. Set the rear tires to have .5-1 degrees of negative camber and ensure that they are adjusted equally, left to right.

5. **Set the front toe-in:**

Adjust the front steering tierods so that when the servo is centered on the transmitter, the front tires are both pointing straight. Refer to the Setup Guide for more information on toe-in/out.

6. **Charge a battery pack:**

Charge a battery pack as per the battery manufacturer's and/or charger manufacturer's instructions so that radio adjustments can be made. Never plug the battery into the speed control backwards.

7. **Adjust the electronic speed control (ESC):**

Following the manufacturer's instructions, adjust your speed control and set the throttle trim on your ESC so that the truck does not creep forward when no transmitter input is applied. Make sure that there is not too much brake being applied when the trigger/stick is in the neutral position. Some speed controls have a high/low setting for the throttle and brake.

8. **Set the transmitter steering and throttle trim:**

The steering trim tab on the transmitter should be adjusted so that the truck rolls straight when you are not touching the steering wheel/stick. If the servo and steering link were installed correctly, the wheels should turn equally to the left and right. If this is not the case, refer to Table 2 and ensure that the steering servo and horn were properly installed. Also check the Steering Link Length as noted in Step F-01. Make sure the throttle trim is set so that the motor does not run when in the neutral position. You may wish to run one "click" of brake to be safe.

## TIPS AND HINTS FROM THE TEAM

Before you start making changes on your XXX-T CR Off Road Racing Truck, you need to make a few decisions. Tires, and how they are setup, have a tremendous impact on overall performance. Before you start making changes on the chassis setup, take a moment to observe a few of the fastest cars at the track and what type of tire and inner liner they are running. When making chassis changes, you should first decide where you feel the car needs to be different. This is commonly referred to as changing the "balance". First decide if the front of the car needs to be adjusted or the back. You will want to work with the rear if the car enters the turn with the front end sticking, and tracking well, while the rear end either does not want to follow, or simply doesn't know what it wants to do. The opposite is true if the rear end seems to want to push the front end through the corners or if the front drives into the corner uncontrollably. You will notice that several different adjustments have similar effects on the handling as well. You will find the best adjustment will become a personal decision based on the "feel" that each of these adjustments yield. This also reflects on the "balance" we referred to earlier. Never make more than one change at a time; if the change you made works adversely, or doesn't address your need, return to the previous position and try something else. Team Losi's development team has put hundreds of hours on the XXX-T CR to arrive at the setup we put in the instruction manual. If you find that you have lost the "handle" go back to the kit (stock) setup, as this setup has proven to be reliable, consistent, and easy to drive.

All of us at Team Losi are sure that you will find the XXX-T CR Off Road Racing Truck to be the most versatile and easiest truck to drive fast, with great consistency. We hope the information in the following guide helps you to enjoy your XXX-T CR Truck, and racing it, as much as we do. For the latest in setup and accessory parts information, visit the Team Losi web site at: [www.teamlosi.com](http://www.teamlosi.com) regularly. For any technical questions go to the "Meet the Team" section of the site. We will try to answer your questions in the order received, to the best of our knowledge, by our own Team Losi R&D race team. Please check the Team Losi web site periodically to find out new setup information as we are always testing on all types of tracks and surfaces. Also note, that there are many ways to setup a truck. The rules we follow can reverse sometimes with different driving styles or different setup styles, so test for yourself and you will find a setup that works right for you.

## Tuning the Transmission of the XXX-T CR

**Differential Adjustment:** Never allow the diff to slip; that's what the slipper is for. Before trying to adjust your diff, you need to tighten the slipper until the spring is fully compressed. Next set the diff setting so it is on the tight side and break the diff in. How you break the diff in is by placing one tire on the tabletop while the other tire is off of the tabletop. Then give the truck about ¼ throttle for 30 seconds. Then do the same thing but place the opposite tire on the tabletop while the other tire is in the air and give the truck ¼ throttle for another 30 seconds. Once that is done you can set the diff. The diff setting will loosen up a little while it is still breaking in and it is important for you to break the diff in prior to driving the truck. Hold the spur gear and right rear tire, then try turning the left rear tire forward. It should be **very** difficult to turn the left rear tire. If the tire turns easily, the diff is too loose. To tighten the diff, line up the slot in the diff screw with the groove in the left out drive. Place the 1/16" Allen wrench through both of these slots. This will lock the diff screw and the out drive together. While holding the Allen wrench in place, turn the right rear tire forward about 1/8 of a turn. Check the differential adjustment again and repeat the tightening process as necessary until the differential is no longer slipping. Do not forget to reset the slipper setting. See "Slipper Adjustment" below, and then continue from here. The final differential adjustment check should be made by placing the truck on carpet, grass, or asphalt and "punching" (quickly applying) the throttle. The differential should not slip. If it does, tighten the diff in 1/8-turn increments as described above until the slippage stops.

Once the diff has been adjusted, it should still operate freely and feel smooth. If the diff screw starts to get tight before the diff is close to being adjusted properly (based on slip), the diff should be disassembled and inspected; you may have a problem with the differential assembly. Refer to the assembly instructions to ensure that the diff is properly assembled and that all parts are properly seated in the assembly.

**Motor Gearing:** The important thing is to keep the motor in its optimal RPM range as much as possible around the entire track. This will depend on the straight-away length and the size of the infield turns. The chart below is a guide to give you a starting point. You may want to try gearing up (larger pinion or smaller spur) or down (smaller pinion or larger spur), one size at a time, noting the straight-away speed and acceleration through the infield.

**\*NOTE: OVER GEARING (TOO LARGE OF A PINION OR TOO SMALL OF A SPUR) or UNDER GEARING (TOO SMALL OF A PINION OR TOO LARGE OF A SPUR) CAN CAUSE DAMAGE TO BOTH YOUR ELECTRONICS AND MOTOR. USE CAUTION WHEN SELECTING YOUR GEARING.**

**Gear Ratio Calculation:** The XXXT-CR includes a 82-tooth, 48-pitch Kevlar® spur gear. The overall internal drive ratio of the transmission is 2.43:1. The pinion gear that is used will determine the final drive ratio. To calculate the final drive ratio, first divide the spur gear size by the pinion gear size. For example, if you are using a 21-tooth pinion gear, you would divide 82 (spur gear size) by 21 (pinion gear size); 82/21=3.90. This tells you that 3.90 is the external drive ratio of the transmission. Next, multiply the internal drive ratio (2.43) by the external drive ratio (in this case 3.90). 2.43x3.90=9.48. This means that by using a 21-tooth pinion gear with a 82-tooth spur gear, the final drive ratio is 9.48:1. Consult your high-performance shop for recommendations to suit your racing style and class. The chart below lists some of the more common motor types and a recommended initial gearing for that motor. Ratios can be adjusted depend on various track layouts, tire sizes, and battery types.

Motor Manufacturer, Make/Model		Spur	Pinion
Stock Motor	EPIC Based Monster	82	19
	EPIC Based Binary (Two Magnet)	82	19
	EPIC Based Binary (Four Magnet)	82	18
	EPIC Based P2K/P2K2	82	19
	TOP Based (Standard Brush)	82	18-19
	TOP Based (V2)	82	18-19
	Yokomo Based	82	18-19
All 19 Turn		82	21-22
Modified Motor	10 Turn	82	17
	11 Turn	82	18
	12 Turn	82	19
	13 Turn	82	20
	14 Turn	82	21
	15 Turn	82	22

Table 3: Suggested gearing.

## Tuning the Front End of the XXXT-CR

**Shock Location:** The XXX-T CR has four mounting locations on the front shock tower. The position can be easily adjusted by simply moving the top of the shock to another hole. The standard location (inside hole on the tower) works best on most tracks. Moving the top of the shock out one hole will result in an increase in steering and will react quicker but will not drive/steer as smoothly, especially on the tighter turns and when you apply throttle exiting turns. Moving the top of the shock inward a hole will slow steering response time and make the truck smoother in bumps. The standard position on the arm is inside which offers the best balance from track to track. When using the middle shock position you will want to move the shock out on the tower to keep the angle same angle as the stock location. A softer spring will be needed when using the middle shock location to obtain the same roll stiffness as well as going to the next largest piston (from #57 to a #56 for example). Running the inside shock location will give the truck more steering into the turn and less steering on corner exit. Running the

shock location outside on the front arm will give you less overall steering into the turn and keep the front end flatter through the turn making the truck smoother and easier to drive. This can be used on high bite tracks. Keep in mind as you move the shocks in on the arm will require internal limiters to obtain the correct suspension travel. For the inside location a total of .200" limiter works great. Team Losi sells a shock spacer set (LOSA5050) that includes .030", .060", .090, and .120" spacers.

**Static Camber:** This refers to the angle of the wheels/tires relative to the track surface (viewed from either the front or back). Negative camber means that the top of the tire leans in toward the chassis. Positive camber means the top of the tire leans out, away from the chassis. Camber can be precisely measured with after market camber gauges, sold at a local hobby shop. It can be measured (roughly) using any square (to the ground) object by checking the gap between the square edge and the top of the tire. Testing has shown that 1 degree of negative camber is best for most track conditions. Increasing negative camber (in the range of 1-2 degrees) will generally increase steering. Decreasing negative camber (in the range of 0-1 degree) will generally decrease steering and the truck will feel easier to drive as a result. This is, most often, a very critical adjustment in tuning your truck that can be made track-side!

**Inboard Camber Location:** The XXX-T CR has three different inner locations with vertical adjustment for the front camber tie rod. In general, the lower or further out the inside position is, relative to the outside, the more camber gain (total camber change through the total throw of the suspension) is present. This is an adjustment that is difficult to make a generic statement for as it can have slightly different results on various conditions. The following is a summary of how this adjustment will usually impact the handling of the XXX-T CR. A longer front camber link will usually make the truck feel stiffer. This will help keep the truck flatter with less roll, but can make the truck handle worse in bumpy conditions, it also will make the truck easier to drive. A shorter front camber link will result in more front end roll, which will provide more steering on tighter turns with the loss of some stability. You will also lose some high speed steering but might gain some more steering response. Too short of a front link may make the truck feel "twitchy" or "wandery" meaning that it may be difficult to drive straight at high speed.

**Inboard Camber Vertical Adjustment:** Washers are often used under the inner ball stud mounting location; this is one of the most important adjustments on the XXX-T CR truck. You should get a feel for how the number of washers affects the handling. Adding washers will make the truck more stable and keep the front end flatter and works well on higher bite tracks.. Removing washers will make the steering more aggressive, which works well on lower bite tracks. This can be good in some conditions, but can also make the truck difficult to drive in others. The best all-around adjustment is with two washers as per the assembly instructions. The washers that are used are included in a assortment package of washers (LOSA6350).

**Outboard Camber Location:** In addition to the inboard camber location the XXX-T CR also provides outboard three mounting options. The middle location is the most used as it provides the best and most consistent handling on different track surfaces. The outer location also helps the truck stay tighter in turns with a more precise steering feel. Moving the link to the inner hole will make the steering react slightly slower and steer smoother. The advantage to the inner hole is that it can increase on power steering and help the truck get through bumps better.

**Toe-In/Out:** This is the parallel relationship of the front tires to one another. Toe-in/out adjustments are made by changing the overall length of the steering tie rods. Toe-in (the front of the tires point inward, to a point in front of the front axle) will make the truck react a little slower, but have more steering from the middle of the turn, out. The opposite is true with toe-out (the front of the tires point outward, coming to a point behind the front axle), the truck will turn into the corner better but with a decrease in steering from the middle of the turn, out. Toe-in will help the truck to "track" better on long straights, where as toe-out has a tendency to make the truck wander. We recommend to run between 0-degree of toe-in/out to 1 degree of toe-in.

**Bump-In/Out:** Bump-out (front of the front tires toe-outward under suspension compression) will result in more off-power steering and less consistent handling if you have too much bump-out. This effect is obtained by adding washers under the steering spindle ball stud. Bump-In (front of the front tires toe-inward under suspension compression) will result in less off-power steering and running too much bump-in can make the steering feel very inconsistent. This effect is obtained by installing a ball stud washer on the bottom of the spindle. Testing has shown that running a little bit of bump-in (kit setup) in the XXX-T CR offers the best overall setup.

**Caster:** This is the angle of the kingpin from vertical when viewed from the side of the truck. The XXX-T CR comes equipped with 30-degree spindle carriers and a 30 degree kick-up angle. Total caster is determined by adding the amount of kick up (XXX-T CR has 30-degrees) and the kingpin angle of the front spindle carriers. Increasing total caster will provide more steering entering a turn but less on exit. Decreasing total caster will cause the steering to react faster and increase on-power steering.

**Variable Length Arm and carrier:** The front arms of the XXX-T CR have the option to have different front arm lengths. The stock position is the short arm length which gives the truck the best balance for most tracks. For most tracks the standard setup will work well, but for extremely bumpy, rutted, and high bite tracks the longer arm length will help slow the reactions of the truck making it feel less twitchy and more stable. For the long front arm length, the spring rate will need to be increased to the next stiffest spring to have the same roll stiffness as the stock settings. The shock piston will also need to be changed to the next size smaller piston (from a #57 to a #60 piston) while keeping the same weight shock oil to keep the same static dampening and pack.

### Tuning the Rear End of the XXX-T CR

**Shock Location:** Moving the top of the shocks outward (from the stock settings) on the tower will provide less rotation in a corner and the truck will become more responsive with increased forward traction. This will also help keep the truck from bottoming out on big jumps. Moving the shocks out on the arm will result in less forward traction and let the truck truckry more of an arc through the exit of the turn. In general, when changing shock locations on the arm, it will be necessary to go down one spring rate when moving out on the arm as well as



going to less pack.

**Static Camber:** Having the same definition as for the front end and measured in the same fashion, rear camber can also be a critical tuning feature. Testing has shown that running a small amount of negative camber (.5-1 degree) is best. Increasing negative rear camber (in the range of 1.5-3 degrees) will increase stability and traction in corners, but decrease high speed stability. Decreasing rear camber (in the range of 0-1.5 degrees) will decrease stability and traction in corners, but will increase high speed stability.

**Inboard Camber Location:** The XXX-T CR has multiple rear camber locations. Using a longer camber link will improve stability and traction (grip). Using a shorter camber link will increase steering while decreasing rear grip. Running the camber link in the inside position (1) on the shock tower will give your truck more steering entering the turn as it will let the truck set over the rear tire and give you more forward traction exiting the turn. As you move the camber link towards the outside of the truck you will gain less initial steering however you will gain more steering as the truck exits the turn. The XXX-T CR now has the capabilities of a lower row of holes in the rear shock tower for the inner camber link location. The lower holes gives the truck more camber gain (more angle relative to arm = more camber gain). This can be helpful when tracks get bumpy and rutted to help the rear end of the truck go through the bumps easier due to the increased camber gain of the tires.

**Outboard Camber Location:** Running the camber link in the inside position (A) on the hub will generate more rotation entering a turn, but decrease steering on exit. Running the camber link in the furthest outer position (C) on the hub will generate more stability entering a turn and increase steering on exit.

**Outboard Camber Vertical Adjustment:** New to the XXX-T CR is the vertical mounted ball stud on the hub. Washers are often used under the outer ball stud to determine the height of the ball stud. Raising the height of the ball stud increases camber gain while lowering the height of the ball stud decreases camber gain. Testing has shown that running the inboard rear camber ball stud in a higher location (less angle relative to arm = less camber gain) on high traction surfaces offers improved stability with decreased rear grip. Also, on low traction surfaces, running the inboard rear camber ball stud in a lower location (more angle relative to arm = more camber gain) will increase rear grip.

**Toe-In:** Having the same definition as for the front end, the toe-in can be adjusted on the XXX-T CR with the rear hubs. The stock toe-in is 3 degrees of inboard per side and 0 degrees in the hub. Increasing rear toe-in will increase forward traction and initial steering, but reduce straightaway speed. Decreasing rear toe-in will decrease forward traction and “free-up” the truck. Less toe-in can be used for stock racing to gain top speed.

**Anti/Pro-Squat:** In the stock configuration, the XXX-T CR has 2 degrees of anti-squat. Increasing anti-squat is generated by raising the front of the pivot block, relative to the rear of the pivot. This will increase initial steering and forward traction. You can increase anti-squat in 1 degree increments by using two .030” washers between the front of the pivot plate and pivot block. Pro-squat is generated by raising the rear of the pivot relative to the front. This will decrease forward traction and initial steering, but provide more on-power steering on high traction tracks. Pro-squat will also help the truck from pulling wheelies on high bite surfaces. Also available is an aftermarket part that is a 0 degree rear pivot block (LOSA2112), if pro-squat is desired it is best to start with this option.

**Variable Length Arm and carrier:** Like the front of the XXX-T CR, the rear end also has variable length arms and carriers. The stock setting is in the short arm location which offers the best balance for most tracks. Moving the hinge pin to the outer location of the arm and hub will give a long arm setting which is suitable for tracks where less rear traction is needed. This can be used on high bite tracks to help settle the truck down from the rear end. For the long rear arm length, the spring rate will need to be increased to the next stiffer spring, the piston will also need to be changed to the next smaller piston (from a #55 to a #56 piston) while using the same shock oil to keep the same static dampening and pack.

### **Tuning the Chassis of the XXX-T CR**

**Slipper Adjustment:** This should be done after the diff is properly adjusted. If you have just finished adjusting the differential, loosen the slipper adjustment nut four full turns. This will be a good starting point for your slipper settings.

**Ride Height:** This is the height of the chassis in relation to the surface of the track. It is an adjustment that affects the way your truck jumps, turns, and goes through bumps. To check the ride height, drop one end (front or rear) of the truck from about a 5-6 inch height onto a flat surface. Once the truck settles into a position, check the height of that end of the truck in relationship to the surface. To raise the ride height, lower the shock adjuster nuts on the shock evenly on the end (front or rear) of the truck that you are working on. To lower the ride height, raise the shock adjuster nuts. Both left and right nuts should be adjusted evenly.

You should start with the rear ride height where the truck comes to a rest at a height where the dog bones are slightly below level with the surface. The front ride height should be set so that the bottom of the chassis is level with the surface. Occasionally, you may want to raise the front ride height to get a little quicker steering reaction but be careful as this can also make the truck easily flip over. Every driver likes a little different feel so you should try small ride height adjustments to obtain the feel you like. We have found that ride height is really a minor adjustment. This should be one of the last adjustments after everything else has been dialed in (tuned). Do not use ride height adjustment as a substitute for a change in spring rate. If your truck needs a softer or firmer spring, change the spring. Do not think that simply moving the shock nuts will change the stiffness of the spring; it will not!

**Battery Position:** This is a critical adjustment that is often overlooked but can be very useful. Start by running the battery spaced in the middle (kit setup). Moving the battery back can improve rear traction on slippery surfaces and steering response. Moving the battery back too far can cause the rear end to swing through turns on some tracks and “dump” the rear end causing instability issues. This is a result of having



Name: _____	Date: _____ Event: _____
City: _____ State: _____	Track: _____

Track Conditions:  Indoor  Tight  Smooth  Hard Packed  Blue Groove  Wet  Low Bite  High Bite  
 Outdoor  Open  Rough  Loose/Loamy  Dry  Dusty  Med Bite  Other \_\_\_\_\_

### Front Suspension

Toe: 1/2°  
 Ride Height: 1.22 in  
 Camber: -1/2°  
 Caster: Stock  
 Sway Bar: No  
 Oil: 30 wt.  
 Piston: 57  
 Spring: Silver  
 Limiters: .210 in  
 Spindle Height: Bottom  
 Axle Spacer: Inside  
 Axle Spacer Size: .100 in  
 Steering Type: Bellcrank  
 Bump Steer: 3 ball stud washers  
 Camber Link: 2-B 2 washers under inner  
 Shock Location: Inside  
 VLA: Short

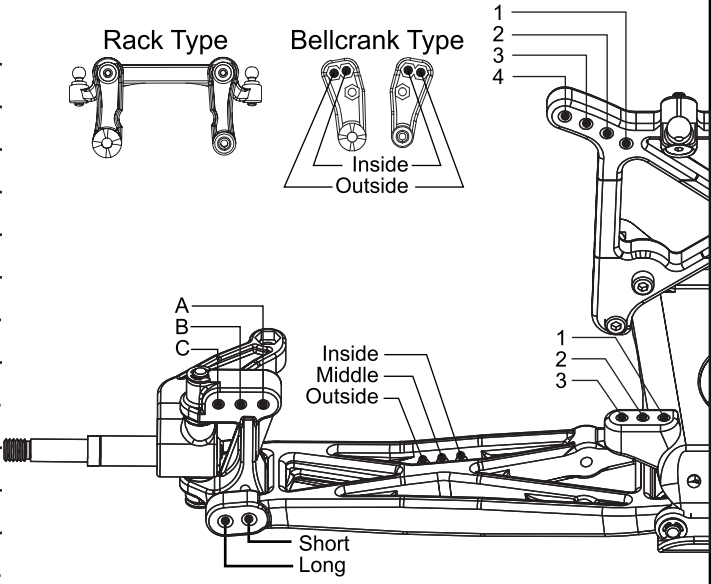

Notes: \_\_\_\_\_  
 \_\_\_\_\_  
 \_\_\_\_\_

### Rear Suspension

Toe: 3°  
 Pivot Support: \_\_\_\_\_  
 Ride Height: 1.18 in  
 Camber: -1°  
 Rear Hub Spacing: Center  
 Drive Shafts/Outdrives: CV/Steel  
 Sway Bar: No  
 Oil: 30 wt.  
 Piston: 55  
 Spring: White  
 Limiters: No  
 Camber Link: 2/B with 3 washers  
 Shock Location: Middle  
 VLA: Short  
 Wing Width & Height: Stock  
 Body Type: Stock  
 Battery Position: Middle

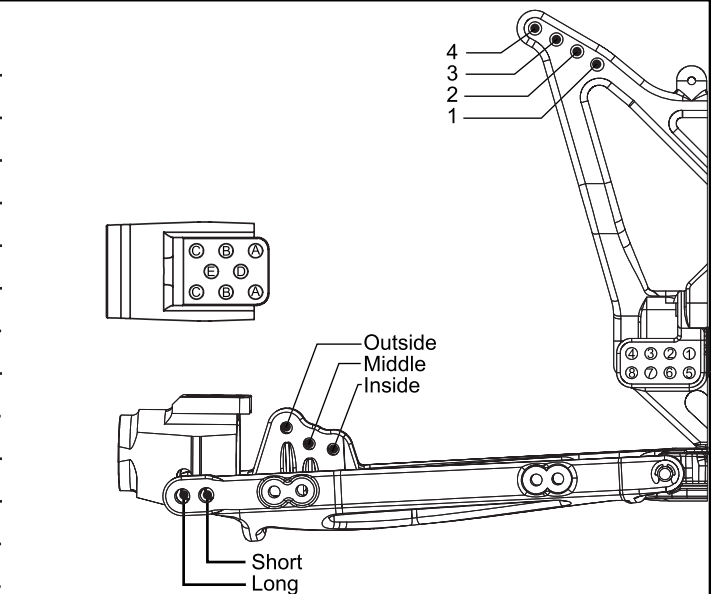

Notes: \_\_\_\_\_  
 \_\_\_\_\_  
 \_\_\_\_\_

Weight Placement (Mark with "X") 	Tires: Type	Compound	Insert	Additive	Motor: _____
	Front: <u>8-Rib</u>	<u>Red</u>	_____	_____	Spur: _____
	Rear: <u>King Pin</u>	<u>Red</u>	_____	_____	Pinon: _____
Notes: _____ _____ _____					

Weight of each piece \_\_\_\_\_ oz.



## Cap Head

- 4-40 x 3/8" (A6206)
- 4-40 x 1/2" (A6204)
- 4-40 x 7/8" (A6216)
- 4-40 x 1-1/8" (A3034)
- 4-40 x 1-1/2" (A3034)
- 3mm x 6mm (A6238)



## Flat Head

- 4-40 x 3/8" (A6210)
- 4-40 x 1/2" (A6220)
- 4-40 x 5/8" (A6233)
- 4-40 x 7/8" (A6226)



## Button Head

- 2-56 x 1/2" (A6236)
- 4-40 x 3/8" (A6229)



## Set

- 5-40 x 1/8" (A6228)
- 4-40 x 5/8" (A6248)



## Ball Bearings

- 3/32" x 3/16" (A6912)
- 5mm x 8mm (A6907)
- 1/8" x 3/8" (A6909)
- 3/16" x 3/8" (A6916)
- 8 x 14 x 4mm (A6945)
- 10mm x 15mm (A6943)
- 1/2" x 3/4" (A6908)



## Ball Studs

- .215" Standard Neck HD (A6025)
- 1/4" Standard Neck HD (A6026)
- 3/8" Standard Neck HD (A6027)
- .345 Short Neck HD (A6029)



## Washers

- Ball Stud (A6215)
- 1/8" x .020" Stainless (A6350)
- 1/8" x .030" Gold (A6350)



## Metal Spacers

- 3/16" x .100" (A3016)
- 3/16" x .240" (A9942)
- 1/2" x .010" (A6230)



## Plastic Spacers

- 1/8" x .050" (A2216)
- 1/8" x 1/16" (.0625") (A5050)
- 1/8" x .140" ("A") (A5015)
- 3/16" x .140" (A3033)



## Roll/Solid Pins

- 1/16" x 3/8" Solid (A3161)
- 1/16" x 1/2" Solid (A3161)
- 3/32" x .930" Solid (A6081)
- 1/8" x .960" Solid (A6086)
- 1/8" x 1.246" Solid (A6088)
- 1/8" x 1.420" Solid (A6089)
- 1/8" x 1.900" Solid (A6092)



## Retaining Clips

- 3/32" E-Clip (A6103)
- 1/8" E-Clip (A6100)
- Body Clip (A8200)



## Nuts (Lock/Plain)

- L 4-40 x 3/16" (Mini) (A6306)
- 4-40 x 1/4" (6300)
- L 4-40 x 1/4" (A6308)
- L 6-40 x 5/16" (A1610)
- L 10-32 x 3/8" (A6303)

## DETAIL ICON REFERENCE KEY

1 These numbers are used to identify the critical order in which assembly must occur. \*Note: They will not call out every stage of the assembly process.

- |                       |                              |                       |                              |  |           |
|-----------------------|------------------------------|-----------------------|------------------------------|--|-----------|
| Apply Loctite®        | Apply Clear Grease           | Apply CA Glue         | Apply Synthetic White Grease | Fill With Silicone Oil                 | Pre-Tap   |
| Pay Special Attention | Cut/Trim                     | Ensure Free Movement  | Ensure Free Rotation         | Ensure Proper Orientation              | Push Firm |
| Side Shown            | Assemble Other Side the Same | Repeat/Build Multiple | Screw Partially              | <b>DO NOT</b> Over Tighten/ Snug Tight | Tighten   |

Name: _____		Date: _____		Event: _____	
City: _____		State: _____		Track: _____	
Track	<input type="checkbox"/> Indoor	<input type="checkbox"/> Tight	<input type="checkbox"/> Smooth	<input type="checkbox"/> Hard Packed	<input type="checkbox"/> Blue Groove
Conditions	<input type="checkbox"/> Outdoor	<input type="checkbox"/> Open	<input type="checkbox"/> Rough	<input type="checkbox"/> Loose/Loamy	<input type="checkbox"/> Dry
		<input type="checkbox"/> Wet	<input type="checkbox"/> Low Bite	<input type="checkbox"/> High Bite	
		<input type="checkbox"/> Dusty	<input type="checkbox"/> Med Bite	<input type="checkbox"/> Other _____	

### Front Suspension

Toe: \_\_\_\_\_  
 Ride Height: \_\_\_\_\_  
 Camber: \_\_\_\_\_  
 Caster: \_\_\_\_\_  
 Sway Bar: \_\_\_\_\_  
 Oil: \_\_\_\_\_  
 Piston: \_\_\_\_\_  
 Spring: \_\_\_\_\_  
 Limiters: \_\_\_\_\_  
 Spindle Height: \_\_\_\_\_  
 Axle Spacer: \_\_\_\_\_  
 Axle Spacer Size: \_\_\_\_\_  
 Steering Type: \_\_\_\_\_  
 Bump Steer: \_\_\_\_\_  
 Camber Link: \_\_\_\_\_  
 Shock Location: \_\_\_\_\_  
 VLA: \_\_\_\_\_

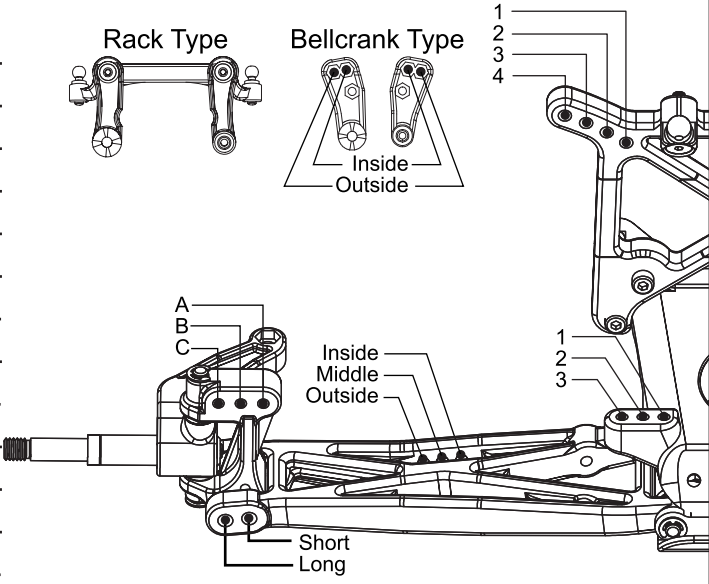

Notes: \_\_\_\_\_  
 \_\_\_\_\_  
 \_\_\_\_\_

### Rear Suspension

Toe: \_\_\_\_\_  
 Pivot Support: \_\_\_\_\_  
 Ride Height: \_\_\_\_\_  
 Camber: \_\_\_\_\_  
 Rear Hub Spacing: \_\_\_\_\_  
 Drive Shafts/Outdrives: \_\_\_\_\_  
 Sway Bar: \_\_\_\_\_  
 Oil: \_\_\_\_\_  
 Piston: \_\_\_\_\_  
 Spring: \_\_\_\_\_  
 Limiters: \_\_\_\_\_  
 Camber Link: \_\_\_\_\_  
 Shock Location: \_\_\_\_\_  
 VLA: \_\_\_\_\_  
 Wing Width & Height: \_\_\_\_\_  
 Body Type: \_\_\_\_\_  
 Battery Position: \_\_\_\_\_

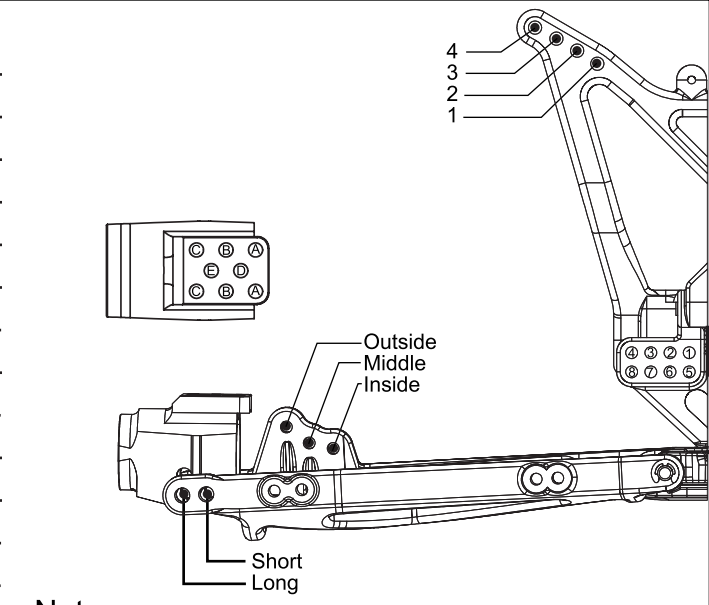

Notes: \_\_\_\_\_  
 \_\_\_\_\_  
 \_\_\_\_\_

Weight Placement (Mark with "X")  Weight of each piece _____ oz.	Tires:	Type	Compound	Insert	Additive	Motor: _____
	Front:	_____	_____	_____	_____	Spur: _____
	Rear:	_____	_____	_____	_____	Pinon: _____
	Notes:	_____				



Team Losi

A Division of Horizon Hobby inc.

4710 E. Guasti Rd.

Ontario, CA 91761

Phone:(909) 390-9595 Fax:(909) 390-5356

[WWW.TEAMLOSI.COM](http://WWW.TEAMLOSI.COM)

Email: [feedback@teamlosi.com](mailto:feedback@teamlosi.com)

800-0341

09-01-07

R.T