

# SPEEDSTAR BRUSHLESS

Thank you for your choosing Robitronic products! Please read this instruction manual carefully to avoid some problems in advance. Also mind the product specs outlined on the packaging.



R01202

## BASIC SETUP

Before you start with the setup procedure, make sure the ESC is plugged into the correct channel and is switched off. The throttle trim on your transmitter should be set to neutral/zero. **Attention:** When the setup seems not possible, please use the servo-reverse function on your transmitter!

- Switch on the transmitter.
- Connect the controller to the battery and turn it on.
- The motor will beep according to the throttle position:  
Do, Re ~ Do, Re, Mi when the throttle is set to neutral  
Do, Re ~ when the throttle is NOT set to neutral

4. **NEUTRAL:** Press the setup-button for more than a second and the green led will start to indicate. Release the button and the green led will start to light continuously. The controller is now calibrated to the neutral position of your TX and the motor beeps (So, So, La, La, La, So, So) for confirmation.

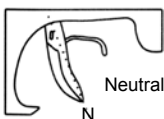

5. **FULL THROTTLE:** Now, put your throttle trigger to full throttle. The red led will light up as the controller confirms the full-throttle position.

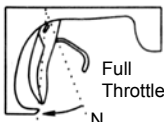

6. **REVERSE/BRAKE:** Lastly, put your throttle trigger to full brake. The red and green leds will light up as the controller confirms the full-brake position.

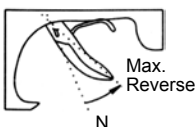

7. Release the throttle trigger and both led will flash alternating, followed by beeps from the motor (So, Fa, Mi, Re, Do) When the green LED lights up permanently, the controller is ready to be used with the new throttle trigger positions.

**Note:** You only need to do the throttle-trigger setup when you start up the controller for the first time, change the throttle trims on your transmitter or use the controller with another transmitter. The basic setup can only be done before the motor is engaged. Press and hold the setup button while turning on.

## ESC FEATURES

- Fully proportional forward/brake with optional reverse.
- Smooth throttle control.
- Suitable for use with sensed and sensorless brushless motors and brushed motors.
- Suitable for use with NiMH (NiCd), Li-Po and Li-Fe batteries.
- Vast amount of brake parameters (Speed-mixing, ABS, drag-brake and brake strength settings)
- Reverse mode can be disabled.
- 2kHz (brushed, brushless sensed) and 32kHz (brushless sensorless) switching frequency for smooth throttle response.
- Thermal protection against overload.

## MOUNTING TIPS

- To avoid interference, mount the ESC at least 2cm away from the receiver and its antenna cable. Also make sure that none of the power wires get closer than this to the receiver and the antenna.
- Always use double sided tape when mounting the ESC. As the controller can get very hot and hence come loose when mounted otherwise

## LED STATUS DISPLAY

Full throttle:	The red led is on
Neutral:	The green led is on
Full brake or reverse:	Both leds are on
Error:	The red led flas

## TECHNICAL SPECS

BRUSHLESS CAR BL ESC	Speedstar BL 8.5
Operating Motor	Brushless and Brushed
Input Voltage	Nicd&NiMH: 4-8cells Lipo/LiFe: 2-3cells
Sensored Brushless System	yes
Sensorless Brushless System	yes
Fwd / Brk/ Reverse	yes
BEC (Volts/amps)	5.0V/3.0A
On-Resistance(Brushless)*	0.005Ω/phase
Rated Current(Brushless)*	260A/phase
On-Resistance(Brushed-Fwd&Brakes)*	0.008Ω
Rated Current(Brushed-Fwd&Brakes)*	780A
On-Resistance(Brushed-Fwd&rev.)*	0.0039Ω
Rated Current(Brushed-Fwd&rev.)*	260A
Motor Limit(Brushless)	Over 8.5 turns
Motor Limit(Brushed-Fwd&Brakes)	Over 6 turns
Motor Limit(Brushed-Fwd&Rev.)	Over 7 turns
Overtemperature Protection	yes
Low voltage cut-off Protection	yes
Overcurrent Protection	no
Power wires	2.0mm
Motor wires	2.0mm
Dimensions(mm)	40.00 X 41.00 X 28.70
Weight	43g

\*at 25°C transistor temperature

## CONNECTING THE ESC

Please make sure that any motor connected to the controller is correctly wired according to the diagram below. Otherwise, the controller may be damaged. The controller may also be damaged, if you keep the soldering iron for more than 5 seconds on the solder joints. Using different kinds of motor, the motor-type parameter from the program-setup must also be adjusted accordingly.

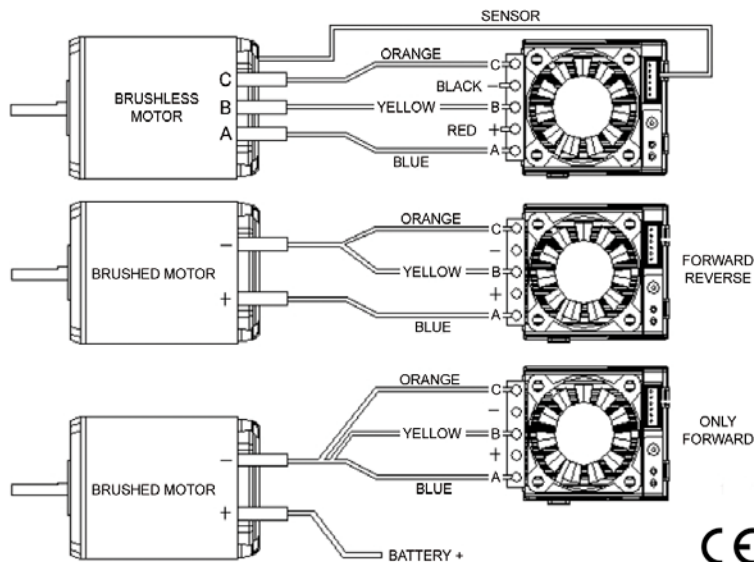

## ERROR DIAGNOSIS

No TX signal:	The red led flashes 1x and lapses for a second.
Undervoltage:	The red led flashes 2x and lapses for a second.
Sensor error:	The red led flashes 3x and lapses for a second.
Overtemperature:	The red led flashes 4x and lapses for a second.

## FURTHER INFORMATION

Please don't use this ESC in damp or even wet conditions as it could take damage.

Don't remove the originally fitted connectors.

Only use high quality, high current connectors with reverse polarity protection. (e.g. 4mm gold plated plugs with sleeves)

This Robitronic product is warranted to be free from defects in materials and workmanship for a period of two years from the purchase date. If there are any defects with materials, workmanship, or assembly of this product, we will gladly repair or replace it for you at our discretion. Products which have been worn out, abused, or improperly operated will not be covered under warranty.

Not covered by warranty:

Normal wear, abuse, neglect, crash damage or any damages arising as a result of improper use.

Robitronic shall not be liable for any loss or damage, whether direct, indirect, incidental, or consequential,

arising from the use, misuse, or abuse of this product and any accessory or chemical required to operate this product.



The WEEE guideline concerning electric and electronic waste recycling has been introduced for protecting health and environment. Complying with this guideline, please do not dispose this product through domestic waste. Instead, ask you local waste site for proper disposal of electric and electronic waste.

## PROGRAM-SETUP

- Switch on the transmitter.
- Connect the controller to the battery and turn it on. (Possible beep-tones: Do, Re, Mi, Fa, So, La, Ti, Do)
- The motor will beep according to the throttle position:  
 Do, Re ~ Do, Re, Mi when the throttle is set to neutral  
 Do, Re ~ when the throttle is NOT set to neutral
- Hold down the setup-button for more than a second and the green led will start to blink for two seconds. Next, the red led will start to flash. Release the setup-button and the motor beeps accordingly (Mi, Re, Do, Re, Mi)  
 The red led will now start flashing in short intervals to indicate the current parameter according to the number of flashes (see below)

- To leave the parameter-setup mode, press the setup-button.

To scroll through the available sets of parameters, put the throttle trigger from neutral to full-throttle and back to neutral. The led flashes accordingly:

1x Motor type	7x Starting power	13x ABS brake
2x Battery type	8x Reverse mode	14x Drag brake
3x Cut-off voltage	9x Reverse delay	15x Minimum brake force
4x Power curve	10x Throttle stick dead band	16x Maximum brake force
5x Motor timing	11x Rotating direction	17x Return to factory settings
6x Acceleration	12x Speed-mixing brake	

The currently active parameter can be accessed when the throttle trigger remains at full throttle for more than 4 seconds. The red and green led start flashing to indicate that the parameter can now be changed. To do so, move the trigger to neutral and then again the full throttle.

- Move the throttle trigger to ½ throttle to stay in the program-setup mode.

- To leave the current parameter-setting menu, leave to throttle trigger at the neutral position for more than 4 seconds. The motor then beeps and the controller returns to the parameter-setup menu where you can select another parameter or leave the parameter-setup by pressing the setup-button.

Below, you'll find a table with the possible parameter settings and the according number of led-flashes in brackets. The factory default setting is listed alongside.

	sensorless (1)	sensored (2)	brushed (3)	factory default
<b>1. Motor type</b>	Li-Po (1)	Li-Fe (2)	NiMH (3)	<b>sensored</b>
<b>2. Battery type</b>	Li-Po (1)	Li-Fe (2)	NiMH (3)	NiMH
<b>3. Cut-off*</b>	<b>auto (1)</b>	<b>3,0V (2)</b>	<b>9,0V (14)</b>	<b>auto</b>
<b>4. Power curve</b>	soft (1)	linear (2)	hard (3)	linear
<b>5. Timing**</b>	<b>0° (1) - 25° (6)</b>	<b>0° (1) - 10° (6)</b>		<b>25° sensorless 10° sensed</b>
<b>6. Acceleration</b>	lowest (1)	highest (5)		highest
<b>7. Starting power</b>	<b>lowest (1)</b>	<b>highest (5)</b>		<b>lowest</b>
<b>8. Reverse-mode</b>	off (1)	on (2)		off
<b>9. Reverse delay</b>	<b>0,2s (1) - 0,5s (2)</b>	<b>0,8s (3) - 1,3s (4)</b>	<b>1,8s (5) - 2,5s (6)</b>	<b>2,5s</b>
<b>10. Dead band</b>	narrow (1)	normal (2)	wide (3)	normal
<b>11. Rotation direction</b>	<b>normal (1)</b>	<b>reverse (2)</b>		<b>normal</b>
<b>12. Speedmix-brake</b>	0% (1) to 100% (11)			0%
<b>13. ABS brake</b>	<b>off (1)</b>	<b>weak (2) - strong (6)</b>		<b>off</b>
<b>14. Drag brake</b>	0% (1) à 100% (11)			0%
<b>15. Minimum brake</b>	<b>0% (1) à 100% (11)</b>			<b>30%</b>
<b>16. maximum brake</b>	0% (1) à 100% (11)			100%
<b>17. Return to factory settings***</b>				

\* The automatic cut-off engages under two conditions, whichever is encountered first:

Li-Po: voltage below 5,5V or below 66% of the voltage when the controller was switched on

Li-Fe: voltage below 5,0V or below 67% of the voltage when the controller was switched on

NiMH: voltage below 5,0V or below 50% of the voltage when the controller was switched on

\*\* Timing for sensorless motors: 1. column, timing for sensed motors: 2. column.

\*\*\* Resetting the controller to its default values still keeps the throttle positions from the basic-setup.

When you are done with the parameter setup, simply turn the controller off and on.

The parameter setup can only be done before the motor is engaged.

## SAFETY PRECAUTIONS

- Never leave your rc-model unattended with its ESC turned on. It could cause a runaway and/or fire.
- Always make sure to use batteries of the appropriate voltage (see packaging)
- Never connect the ESC in reverse polarity. Always use plugs that are protected against reverse polarity and properly shrink wrap all connections to avoid a short circuit.
- Never let the motor run off a separate battery when the ESC is connected. This will destroy the ESC!
- Always switch on the transmitter first, and then the ESC. Doing otherwise may cause a runaway
- Avoid locked up tyres or motors
- Never touch the heat sink immediately after driving as it can get very hot!
- Not suitable for children under age 14 - this product is not a toy!

## TROUBLE-SHOOTING

**Problem:** Motor and steering servo do not react.

- The battery is empty -> recharge the battery
- Bad connection -> recheck all connections
- Connected in reverse polarity -> immediately disconnect and reconnect with proper polarity
- Internal damage -> send the ESC to the service department

**Problem:** No reverse function.

- Transmitter or the ESC are not properly adjusted -> Recheck all settings
- Internal damage -> send the ESC to the service department

**Problem:** Motor cogs and stutters.

- Defective battery -> try again with another battery
- Receiver is mounted too close to the ESC -> mount the receiver further away from the ESC

**Problem:** Motor stalls after a few minutes

- The ESC's thermal protection is active  
 -> make sure that the drivetrain moves freely  
 -> choose a higher transmission ratio (e.g. smaller pinion gear)